

Ultra-tec[®]

CABLE RAILING INFILL

INSTALLATION GUIDE

April 1, 2015



G&F Southeast Distributors, Inc
PO Box 2588
Peachtree City, GA 30269
866-830-3021

(706) 538-0883
Fax (866) 712-1198

e-mail: don.goddard@gmail.com
www.southeastdistributors.com

TABLE OF CONTENTS

	Page
Before You Get Started	
Rail Finish.....	IG-1
Materials Required.....	IG-1
Tools Required.....	IG-1–IG-2
Installing Grommets	IG-2
Measuring and Installing Cable—Horizontal Railings	
Measuring Cable Lengths.....	IG-3
Installing Cable.....	IG-4–IG-14
Tensioning Cables.....	IG-14
Wood Railings—Mounting Alternatives/Hole Drilling	IG-15–IG-17
Measuring and Installing Cable—Vertical Railings	IG-18–IG-20
Swaging Instructions	IG-20–IG-23
Ultra-tec® “Clip-On” Fixed Jaw Installation Instructions	IG-23
Using Invisiware® Receivers on Stairways	IG-24–IG-25
Ultra-tec® “Clip-On” Stop Installation Instructions	IG-26
Push-Lock® Fittings Installation Instructions	IG-27–IG-29
Pull-Lock® Stop-End Fittings Installation Instructions	IG-30–IG-31
Receiver with Push-Lock® Stud Installation Instructions	IG-32–IG-37
Push-Lock® Turnbuckle Installation Instructions	IG-38–IG-41
PL-Key Instructions	IG-42

Ultra-tec®, Invisiware®, Adjust-A-Body®, Adjust-A-Jaw®, Push-Lock® and Pull-Lock® are registered trademarks of The Cable Connection, Carson City, NV 89706.

© 2015 The Cable Connection, Carson City, NV 89706. All rights reserved.

BEFORE YOU GET STARTED

Rail Finish

If your rail is to be painted, powder coated or otherwise finished in any way, we strongly recommend that you apply the finish after all holes are drilled and prior to stringing the cable.

Materials Required

Some parts require screws to mount them to your railing. If they were not ordered from the factory, then you will need to obtain mounting screws for the parts shown in the chart below.

PART NUMBERS	FOR CABLE DIAMETER	SCREW REQUIRED	FACTORY PART NO.*
Adjust-A-Jaw® Tensioners			
A-J62	1/8" or 3/16"	1/4-28 x 1/2"	SC-6
A-J82 A-J122	1/4", 5/16", 3/8"	3/8-24 x 3/4"	SC-8
Adjust-A-Body® with Threaded Eye Tensioners			
A-JTE6	1/8" or 3/16"	1/4-28 x 1/2"	SC-6
A-JTE8	1/4"	3/8-24 x 3/4"	SC-8
Push-Lock™ with Threaded Eye Fittings			
PL-TE4	1/8"	1/4-28 x 1/2"	SC-6
PL-TE6	3/16"		

*Factory supplied screws are stainless steel button-head screws.

In areas prone to tampering, a permanent setting thread sealant is recommended for use with screws.

Tools Required

The tools listed here assume you will be swaging at least one end of the cable in the field using an Invisiware field swager. If no field swaging is required, only those tools indicated with * may be required.

***Cable Cutters.** C9 for cables up to 3/16"; C12 for cables larger than 3/16".

Air Compressor.

Minimum 5.8 c.f.m. at 90 p.s.i. and a minimum 20 gallon tank. Air pressure should be regulated to a minimum of 120 p.s.i., not to exceed 140 p.s.i.

Ultra-tec Portable Pneumatic/Hydraulic Swager.

(If you are renting one from the factory or a factory representative, be sure to specify the uncoated diameter of the cable you are swaging, so the correct swager will be supplied. Rented swagers generally come with most other special tools required to field



^ **Model 610 Swager kit for 1/8" and 3/16" cable.**

< **Model 650 Swager for 1/8" through 3/8" cable.**



> **Electric Hydraulic 120V Pump**

IG-1
4/1/15

Ultra-tec®
CABLE RAILING INFILL

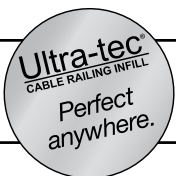

1-800-851-2961 ■ 775-885-1443 ■ Fax 775-885-2734
52 Heppner Drive ■ Carson City, NV 89706
E-mail: info@ultra-tec.com Website: www.ultra-tec.com

Tools Required (continued)

swage and install cable, including hose fittings, cable grip locking pliers, cable cutter, and GO gauge for measuring the swaged diameter of Invisiware Radius Ferrules. A pre-tensioner can also be furnished upon request.)

*Ultra-tec Pre-tensioning Tool (optional).

Since some Invisiware hardware has a minimum of take-up on longer runs (over 30 feet) you may want to use a pre-tensioning tool. In ordering, be sure to specify the cable diameter you will be using it with.

***Cable Grip Locking Pliers.** To grip the cable while tensioning the end fittings without damaging the cable. (Available from the factory).

***Wrenches.** If installing Invisiware Receivers (including when they are used with Push-Lock Studs), an Allen wrench to tension the cable. See chart below.

PART NUMBERS	FOR CABLE DIAMETER	HEX HOLE SIZE
R-6-12 thru R-6-62	1/8" or 3/16"	3/16"
R-8-22 thru R-8-52	1/4"	7/32"
R-12-32 thru R-12-52	5/16" or 3/8"	5/16"

If installing Adjust-A-Jaw, Adjust-A-Body, or Push-Lock Stud tensioners, an open-end wrench to tension the cables. See chart below.

TENSIONER PART NUMBERS	FOR CABLE DIAMETER	OPEN-END WRENCH SIZE
Adjust-A-Jaw		
A-J62	1/8" or 3/16"	7/16"
A-J82 A-J122	1/4", 5/16", 3/8"	11/16"
Adjust-A-Body		
ANY	1/8" or 3/16"	7/16"
ANY	1/4"	9/16"
Receiver with Push-Lock Stud		
PLST-4, PLST-6	1/8" or 3/16"	3/8"
Push-Lock Turnbuckle		
ANY	1/8" or 3/16"	3/8" and two 7/16" wrenches

If installing Adjust-A-Body with Hanger Bolt Tensioners, an open-end wrench or hanger bolt driver installation tool to install the hanger bolts into the wood post.

PART NUMBERS	FOR CABLE DIAMETER	OPEN-END WRENCH SIZE
A-JB6	1/8" or 3/16"	1/4"
A-JB8	1/4"	3/8"

Calipers, if you are swaging and installing Invisiware Radius Ferrules, you will need a means to measure the diameter of the swaged fitting. ("GO" gauges for this purpose are normally included with Ultra-tec Portable Swagers when rented from the factory).

Grommet Installation Tool (available from the factory), and **hammer** if you will be installing grommets.

***Drills and Drill Bits** as required, if installing in a wood railing—see *Wood Railings* under "Measuring and Installing Cable—Horizontal Railings".

***Cut-off Kit**, if using Pull-Lock fittings.

INSTALLING GROMMETS

IMPORTANT NOTE: If grommets are being used on intermediate posts, cable braces, or in the cable exit hole of end posts, then grommets should be installed before cable is run.

To install grommets, see Fig. K below. Place the larger diameter of the grommet onto the grommet installation tool and the smaller diameter at the hole in the post. Tap the tool *lightly* with a hammer.

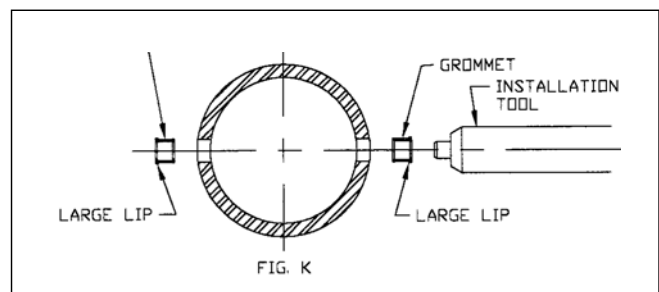

MEASURING AND INSTALLING CABLE

Horizontal Railings

Measuring Cable Lengths

This section applies only if you will be cutting and swaging the cables. If you have ordered your cables cut to length with fittings already swaged on, or you are using swageless fittings (Pull-Lock, Push-Lock, Receiver with Push-Lock Stud, Push-Lock Turnbuckle), you can skip this section on "Measuring Cable Lengths."

Measure the length of the run from the outside of one terminating end post to the other terminating end post. Over estimate when corners are involved. See Figures A and B below.

Note that Post A is always the first end to which hardware is attached. When only one end has a tensioning device (Invisiware Receiver, Adjust-A-Jaw or Adjust-A-Body tensioner) that tensioning device is attached to Post B and the non-tensioning device is attached to Post A. Post B is always a tensioning end.

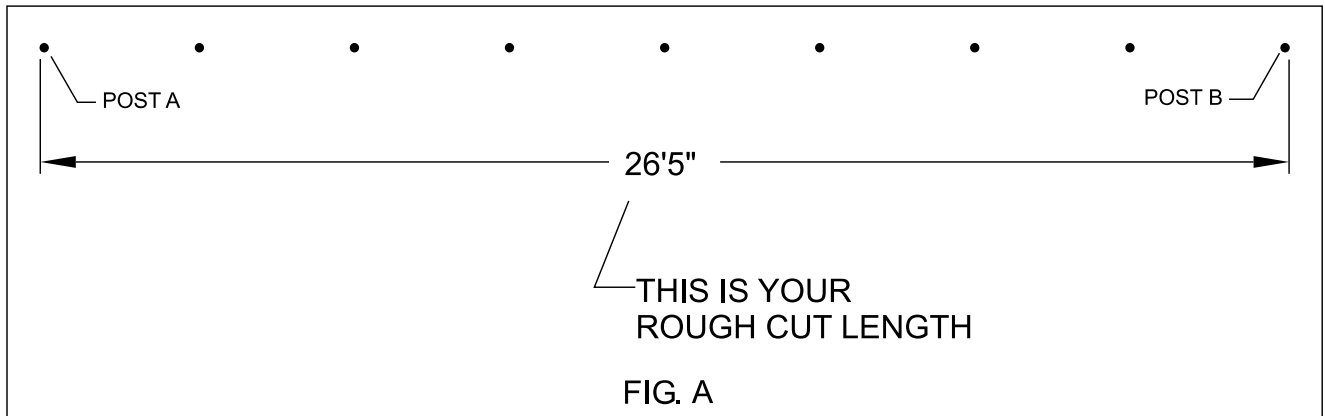

Measure out cable on a relatively clean surface (see Figure B below). A lawn or swept concrete surface would be fine. Cut cable to length using Cable Cutter.

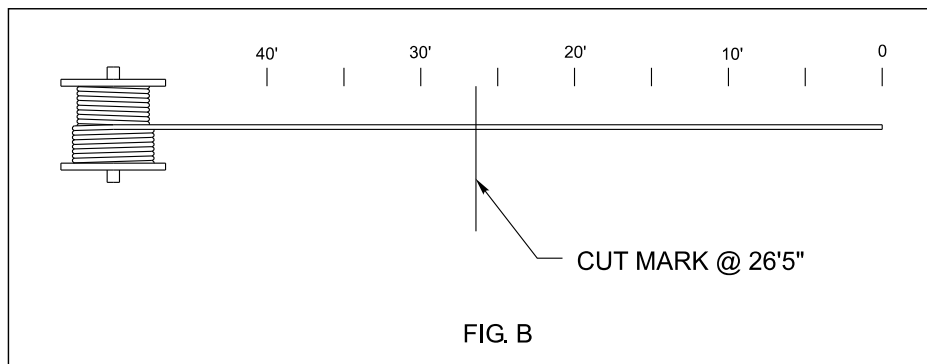

Note: Make sure you have a positive holding device at the zero end. Cutting the cables takes very little time. It is best to have one person stand at the zero end while another operates the cable cutter at the cut mark.

Installing Cable (continued)

IF YOU ARE USING PUSH-LOCK OR PULL-LOCK FITTINGS, RECEIVERS WITH PUSH-LOCK STUDS, OR PUSH-LOCK TURNBUCKLES, SEE SEPARATE INSTRUCTIONS FOR THOSE FITTINGS (pages IG-28 through IG-41).

NOTE: Where only one end of the cable has an adjusting fitting (Invisiware Receiver or Adjust-A-Jaw or Adjust-A-Body tensioner), we recommend that you **swage the unadjusting end, Post A, first** (before the cables are strung) and the adjusting end, Post B, last (after the cables have been strung).

A. Unless already swaged (attached to the cables), swage the fittings to be used onto one end of the cut cables (see "Swaging Instructions," pages IG-20 to IG-23).

Where Invisiware Radius Ferrules will be used, 1) Slide the washer onto the cable; 2) swage the Radius Ferrule onto the end of the cable (see "Swaging Instructions," pages IG-20 to IG-23); 3) slide the washer over the body of the Radius Ferrule; 4) feed the bare end of the cable through the hole in Post A from the back side, until the fitting's head with washer rests against the back side of the post (or in the counterbore if applicable).

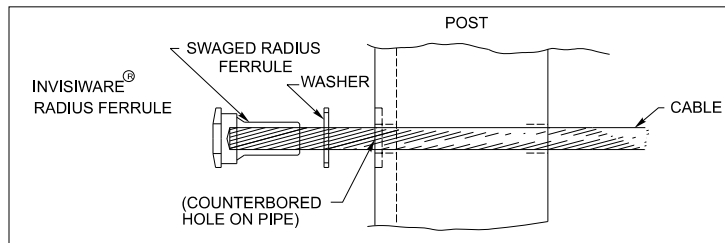

Where Invisiware Receivers are being used, swage the Stud onto the end of the cable to be attached to Post A (see "Swaging Instructions," pages IG-20 to IG-23).

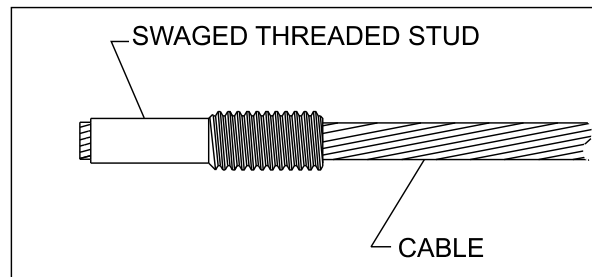

Where Adjust-A-Jaw or Adjust-A-Body Type Tensioners are being used, slide the Body onto the cable and swage the Ferrule onto the end of the cable to be attached to Post A (see "Swaging Instructions," pages IG-20 to IG-23).

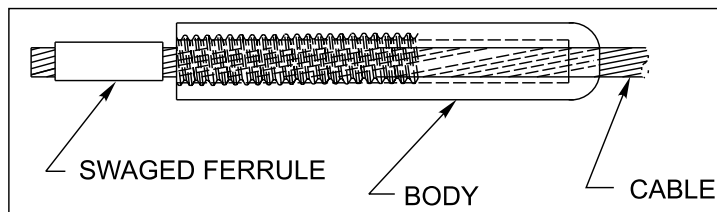

Installing Cable (continued)

Where Ultra-tec Fixed Jaws are being used, slide the Fixed Jaw onto the cable and swage the Ferrule onto the end of the cable to be attached to Post A (see "Swaging Instructions," pages IG-21 to IG-24).

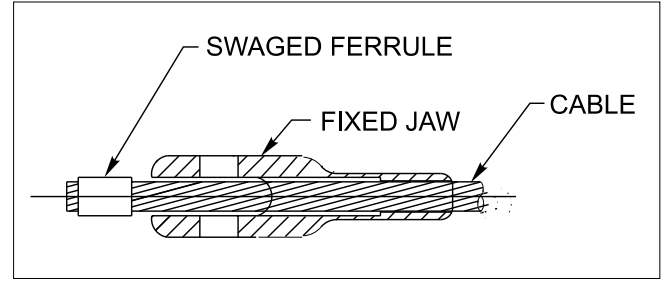

NOTE: If you are using Ultra-tec "Clip-on" Fixed Jaws with the Ferrule already swaged onto the cable or Ultra-tec "Clip-on" Stops you will have to feed the cable from the Post B end through all intermediate posts to Post A, before installing the Fixed Jaw onto the Post A end of the cable. See "Ultra-tec Clip-On Fixed Jaw Installation Instructions" (page IG-23) or "Ultra-tec "Clip-on Stop Installation Instructions" (page IG-26) for attaching the Fixed Jaw or "Clip-on Stop" to the cable.

B. String cable through intermediate posts and braces to Post B.

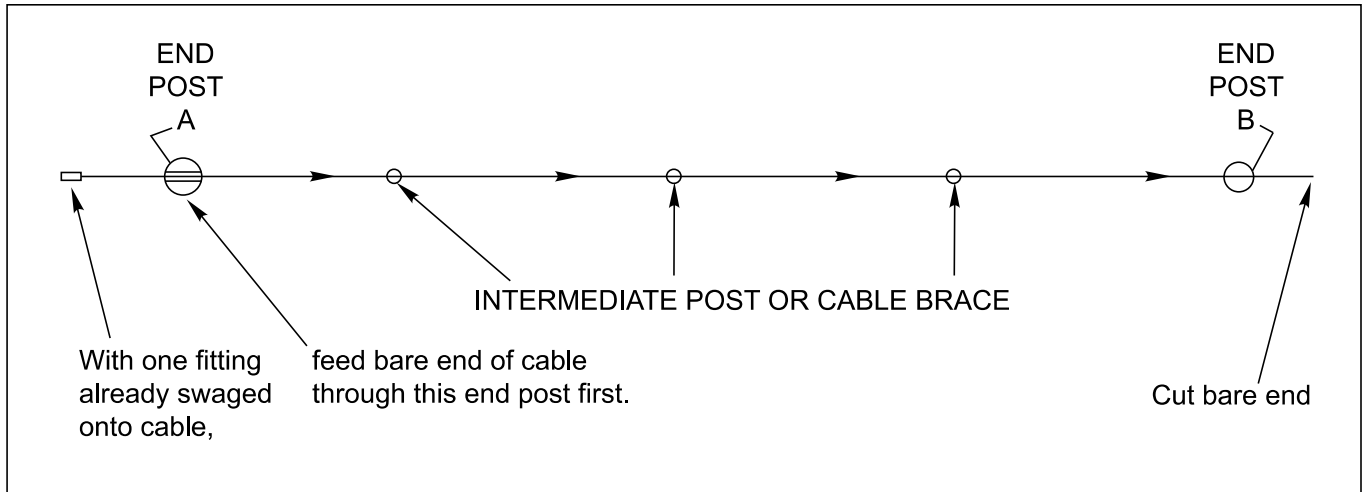

Installing Cable (Continued)

C. Attach fittings to end Post A.

If using **Ultra-tec Fixed Jaw** bolt the fitting to the tab, through the hole in the structural tee, or the lag eye (in wood post) on the end post, using the screws specified under "Materials Required."

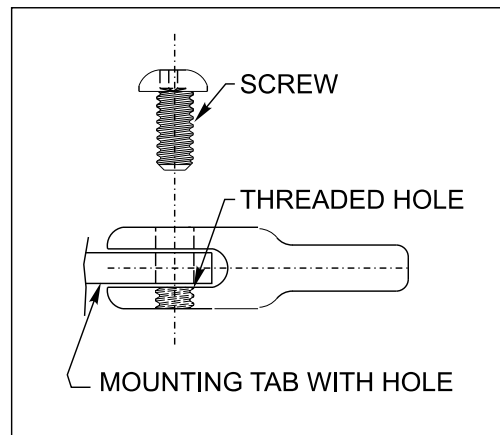

If using **Adjust-A-Jaw** or **Adjust-A-Body** with **Threaded Eye Tensioners**:

If you are installing the tensioner using tabs, holes in a structural tee or lag eyes (in wood) attach the clevis portion of the fitting to the tab, lag eye or through the hole in structural tee on the end post, using the screws specified under "Materials Required."

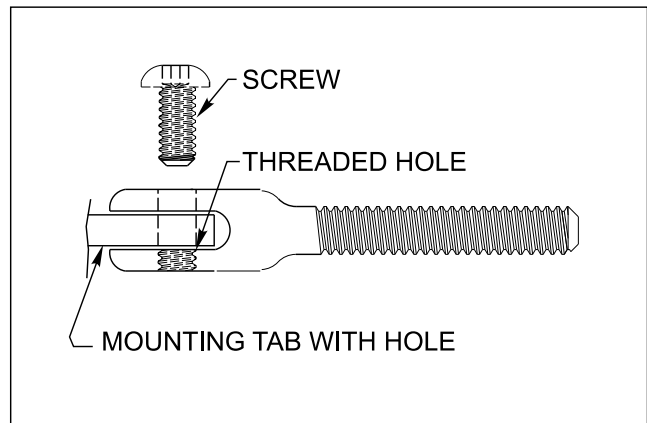

Screw the lock nut onto the threads of the Clevis or Eye, then hold the cable closely behind the body and turn the body by hand at least 6 full turns onto the threaded end of the Clevis. (See note on page IG-7).

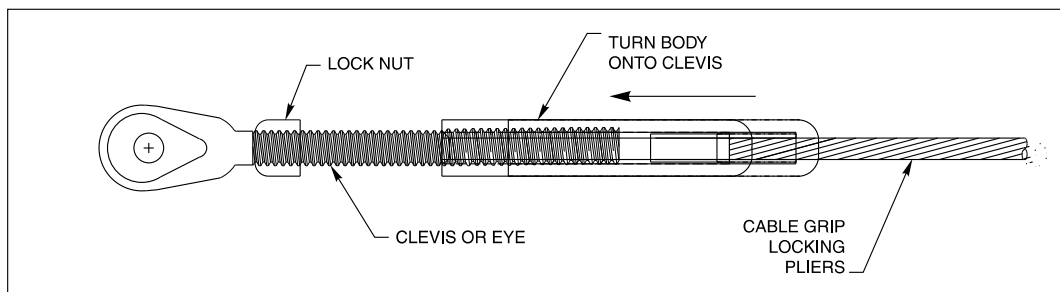

IG-6
4/1/15

Ultra-tec[®]
CABLE RAILING INFILL

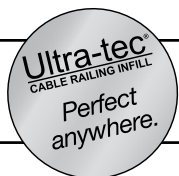

1-800-851-2961 ■ 775-885-1443 ■ Fax 775-885-2734
52 Heppner Drive ■ Carson City, NV 89706
E-mail: info@ultra-tec.com Website: www.ultra-tec.com

Installing Cable (Continued)

If you are installing into wood with a hanger bolt, screw the hanger bolt into a pre-drilled pilot hole in the post. Screw the lock nut onto the threads of the bolt, then hold the cable closely behind the body and turn the body by hand at least 6 full turns onto the threaded end of the bolt. (See note below)*

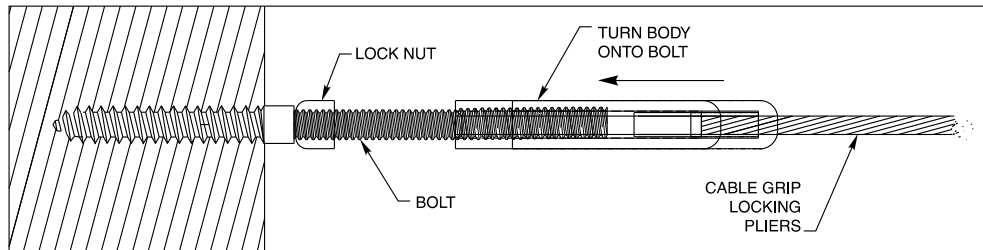

If you are installing into a threaded hole in a metal post, screw the bolt into the threaded hole in the post. Screw the lock nut onto the threads of the bolt, then hold the cable closely behind the body and turn the body by hand at least 6 full turns onto the threaded end of the bolt. (See note below)*

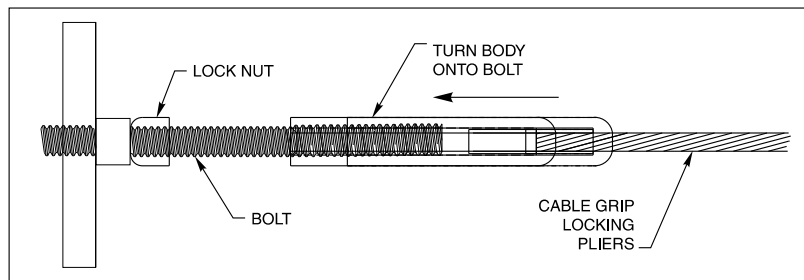

If you are installing an Adjust-A-Body concrete anchor bolt end into a concrete anchor bolt, screw the bolt into the threaded hole in the anchor bolt. Screw the lock nut onto the threads of the bolt, then hold the cable closely behind the body and turn the body by hand onto the threaded end of the bolt at least 6 full turns. (See note below)*

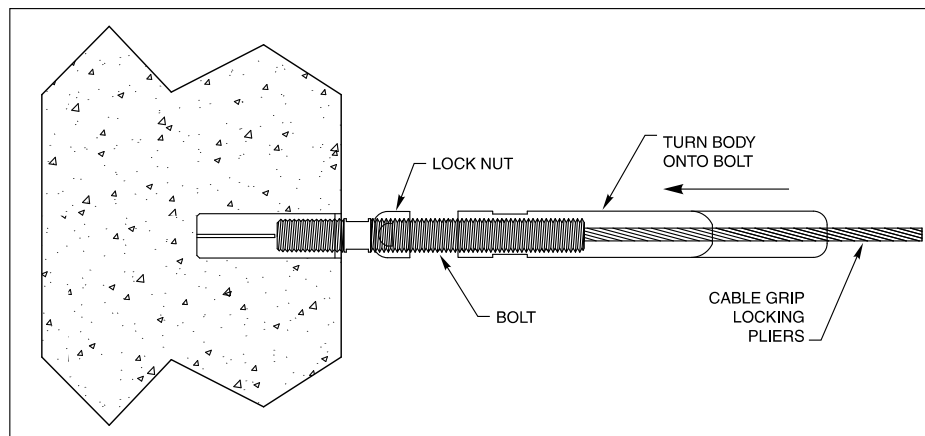

***NOTE:** This will allow for maximum take-up. The fewer turns you make at this step, the more thread that will be exposed when the installation is complete. Each job is different, so we suggest that you string and lightly tension one cable between end posts, to determine how many turns you will make in turning the body onto the male threaded end in order to minimize the amount of exposed thread at both ends.

IG-7
4/1/15

Ultra-tec[®]
CABLE RAILING INFILL

Ultra-tec[®]
CABLE RAILING INFILL
Perfect
anywhere.

1-800-851-2961 ■ 775-885-1443 ■ Fax 775-885-2734
52 Heppner Drive ■ Carson City, NV 89706
E-mail: info@ultra-tec.com Website: www.ultra-tec.com

Installing Cable (Continued)

If using Invisiware Receiver, slide the washer over the body of the Receiver, then feed the Receiver through the hole in back of the post and into the hole on inside wall of the post (metal). If you have a metal double post end post construction, be sure to place spacers between the double posts, as you feed the fitting through. By hand, screw the Receiver onto the threaded Stud at least 6 full turns.

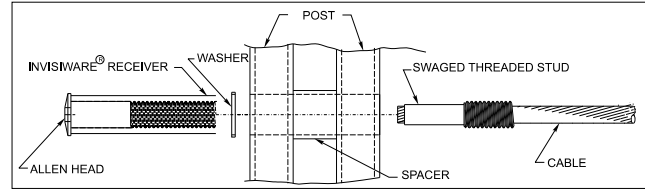
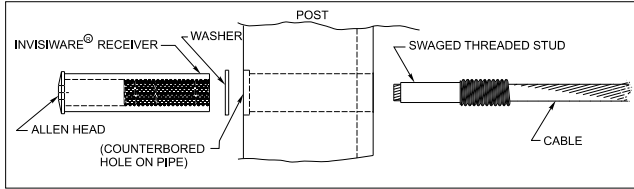

DOUBLE END POST CONSTRUCTION

For wood posts, follow the same instructions, except you will have to feed the cable (with the Stud swaged on the end) through the post from the inside to meet the Receiver inside the post, where you will turn the Receiver onto the Stud using an Allen wrench.

If you are using Invisiware Radius Ferrule, make sure the fitting is through the hole in the back of the post with the head with washer resting against the back side of the post (or in the counterbore if applicable) as you proceed to the next step.

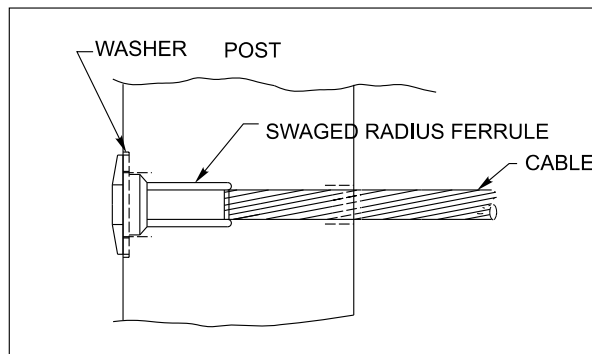

D. Pull cable toward end Post B. Use Ultra-tec Pre-tensioning Tool, if required (see below).



IG-8
4/1/15

Ultra-tec®
CABLE RAILING INFILL

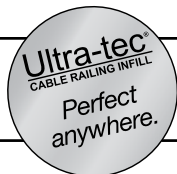

1-800-851-2961 ■ 775-885-1443 ■ Fax 775-885-2734
52 Heppner Drive ■ Carson City, NV 89706
E-mail: info@ultra-tec.com Website: www.ultra-tec.com

Installing Cable (Continued)

E. Attach fittings at end Post B

If installing Invisiware Receiver at Post B

NOTE: If installing Invisiware Receiver on a stairway, see "Using Invisiware Receivers on Stairways" before proceeding.

1. Cut Cable at Post B end. (Assumes cable is already attached to Post A.)

Mark and cut the cable at the location shown in relation to end Post B (see Figure R below for steel posts, Figure RW below for wood posts). *NOTE: this cut mark will allow for maximum take-up. However, it may leave more thread exposed than necessary after tensioning. This length can be altered to achieve the most favorable results.*

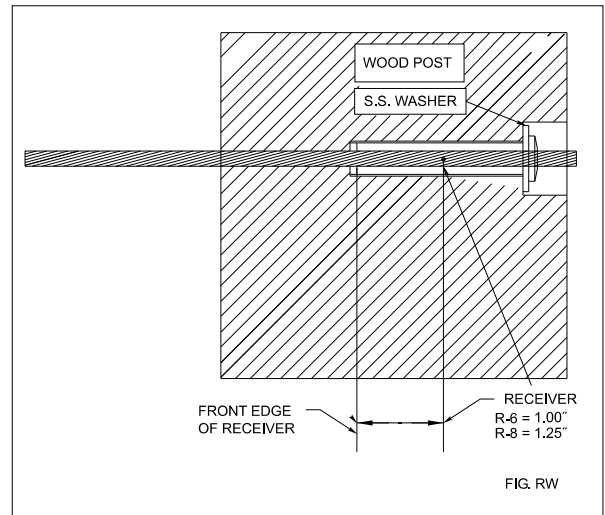
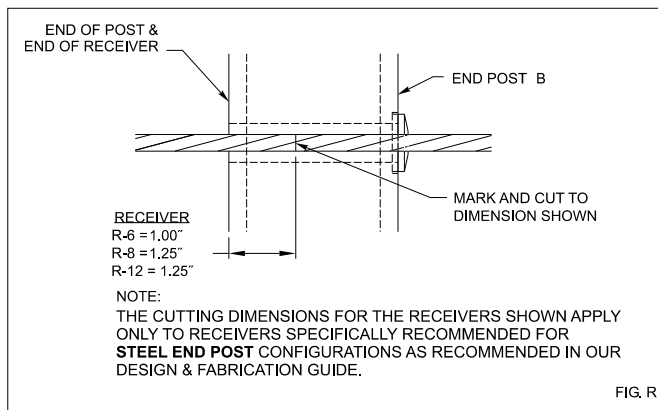

2. Swage Stud onto cable (see "Swaging Instructions," pages IG-20 to IG-23).
3. Slide the washer over the body of the Receiver, then feed the Receiver through the hole in the back of the post. If you have a double post end post construction, be sure to place spacers between the double posts, as you feed the fitting through. By hand, screw the Receiver onto the swaged Stud at least 6 full turns. Do not tension cables until all cables have been installed between end posts A and B.

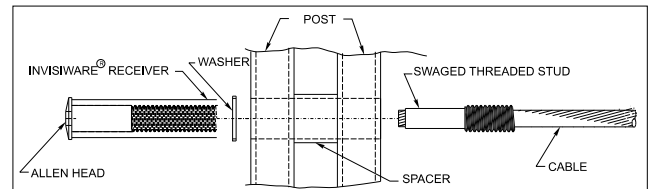
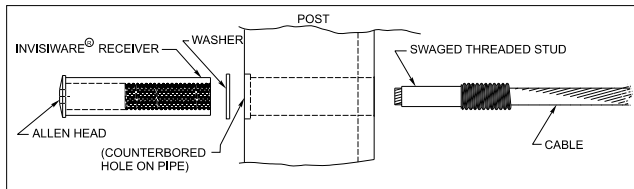

DOUBLE END POST CONSTRUCTION

For wood posts, follow the same instructions, except you will have to feed the cable (with the Stud swaged on the end) through the post from the inside to meet the Receiver inside the post, where you will turn the Receiver onto the Stud using an Allen wrench.

Installing Cable (Continued)

- Repeat above steps for each cable to be installed between end posts A and B.
- After all the cables have been installed, tension the cable (to between 300 and 400 lbs.) by holding the cable (using cable grip locking pliers) closely behind the Stud. Turn the Receiver clockwise with an Allen wrench (see Figure U). See "Tensioning Cables" (page IG-14) for sequence to use in tensioning cables.



If installing Adjust-A-Jaw or Adjust-A-Body type tensioner at Post B

- Cut cable at Post B end. (Assumes cable is already attached to Post A).

If you are attaching the tensioner to a tab, lag eye or hole in a structural tee, mark and cut the cable at the location shown in relation to the center of the mounting hole at Post B (see Figure T below).

NOTE: this cut mark will allow for maximum take-up. However, it may leave more thread exposed than necessary after tensioning. This length can be altered to achieve the most favorable results.

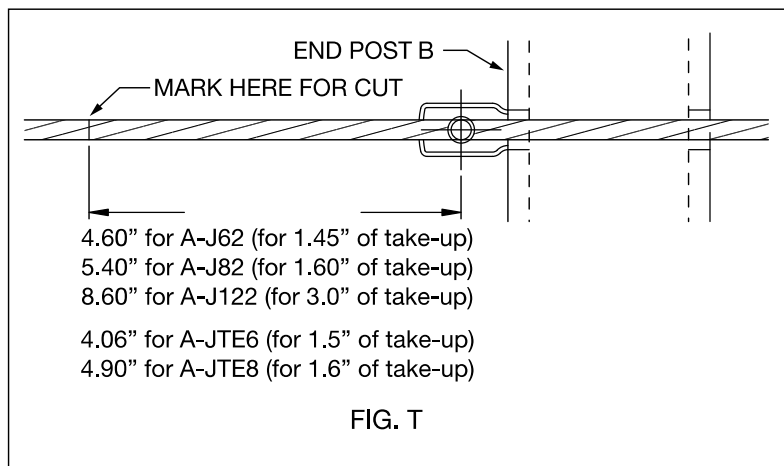

Installing Cable (Continued)

If the tensioner is mounted with the bolt screwed into a wood post, a threaded hole in a metal railing, or a concrete anchor, mark and cut the cable at the location shown in relation to end Post B (see figures below). NOTE: this cut mark will allow for maximum take-up. However, it may leave more thread exposed than necessary after tensioning. This length can be altered to achieve the most favorable results.

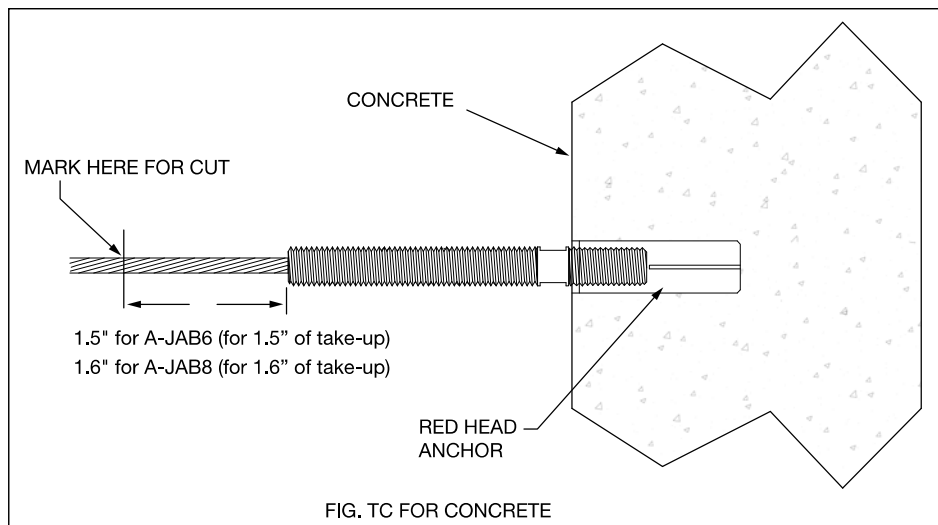
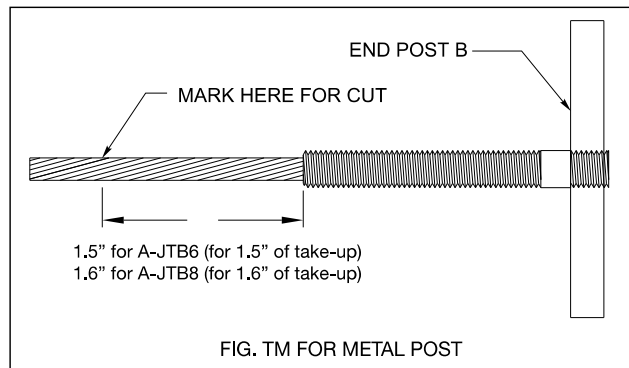
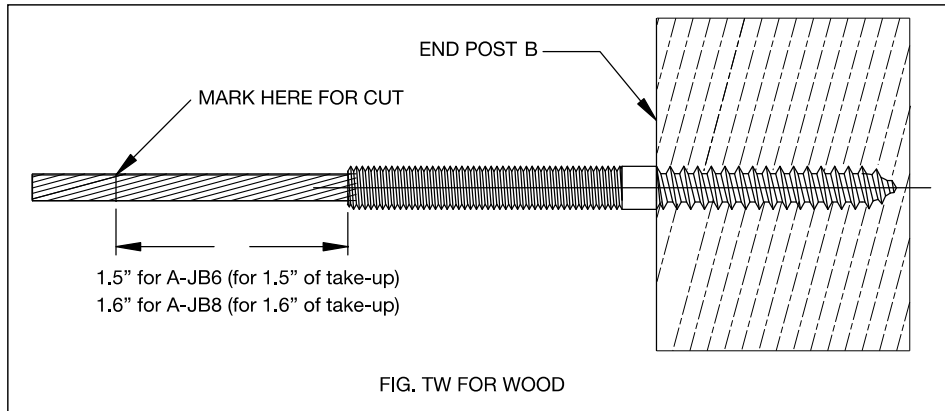

IG-11
4/1/15

Installing Cable (Continued)

- Slide the Body onto the cable and swage the Ferrule onto the end of the cable (see "Swaging Instructions," pages IG-20 to IG-23).

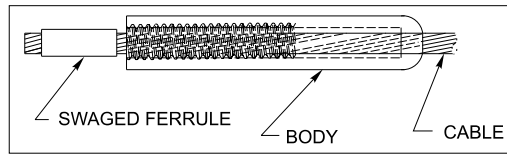

- Attach Tensioner to Post.

If you are installing the tensioner using tabs, holes in a structural tee or lag eyes (in wood) attach the Clevis or Eye portion of the fitting to the tab, lag eye or through the hole in structural tee on the end post, using the screws specified under "Materials Required."

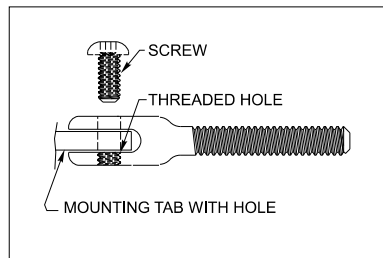

Screw the lock nut onto the threads of the Clevis or Eye, then hold the cable closely behind the body and turn the body by hand onto the threaded end of the Clevis at least 6 full turns.

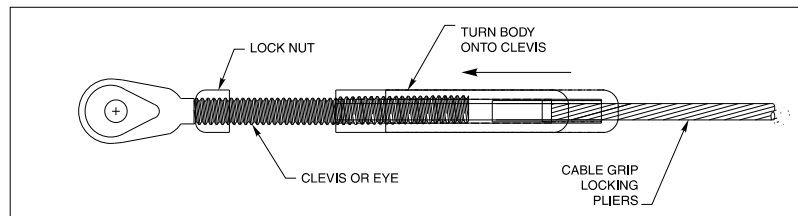

If you are installing into wood with a hanger bolt, screw the hanger bolt into a pre-drilled pilot hole in the post. Screw the lock nut onto the threads of the bolt, then hold the cable closely behind the body and turn the body by hand onto the threaded end of the bolt at least 6 full turns.

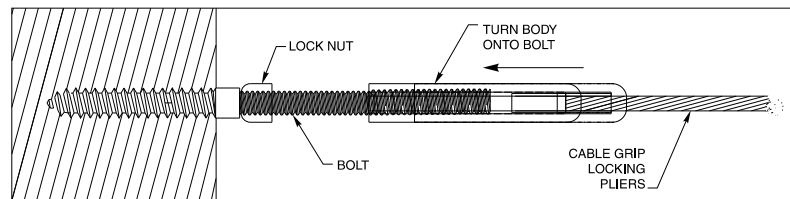

Installing Cable (Continued)

If you are installing into a threaded hole in a metal post, screw the bolt into the threaded hole in the post. Screw the lock nut onto the threads of the bolt, then hold the cable closely behind the body and turn the body by hand onto the threaded end of the bolt at least 6 full turns.

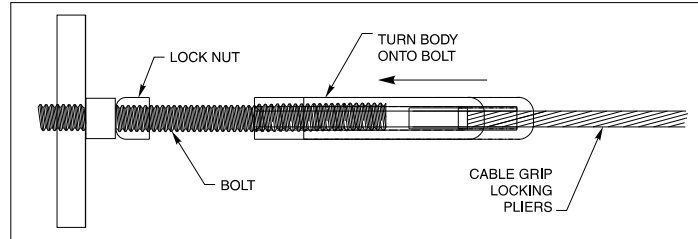

If you are installing an Adjust-A-Body concrete anchor bolt end into a concrete anchor bolt, screw the bolt into the threaded hole in the anchor bolt. Screw the lock nut onto the threads of the bolt, then hold the cable closely behind the body and turn the body by hand onto the threaded end of the bolt at least 6 full turns.

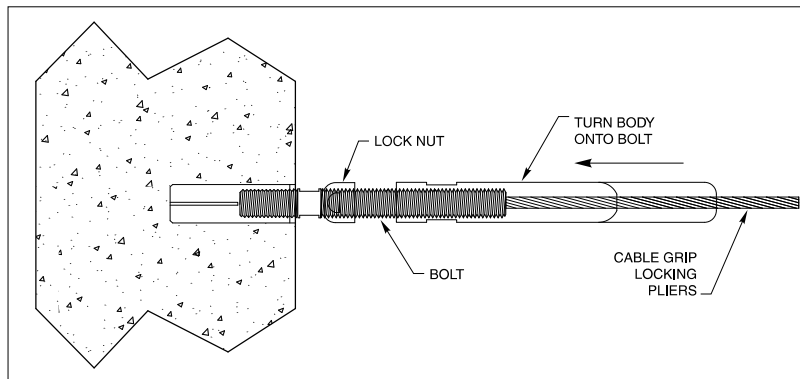

4. Repeat the above steps for each cable to be installed. Do not tension the cables, until all cables have been installed between end posts A and B.
5. After all the cables have been installed, tension the cable (to between 300 and 400 lbs.) with an open end wrench, holding the cable with cable grip locking pliers to prevent it from rotating (see illustration below). See "Tensioning Cables" (page IG-14) for sequence to use in tensioning cables.



IG-13
4/1/15

Ultra-tec[®]
CABLE RAILING INFILL

Ultra-tec[®]
CABLE RAILING INFILL
Perfect
anywhere.

1-800-851-2961 ■ 775-885-1443 ■ Fax 775-885-2734
52 Heppner Drive ■ Carson City, NV 89706
E-mail: info@ultra-tec.com Website: www.ultra-tec.com

Installing Cable (Continued)

- If tensioners are mounted to tabs, structural tees or lag eyes, tighten the mounting screws.

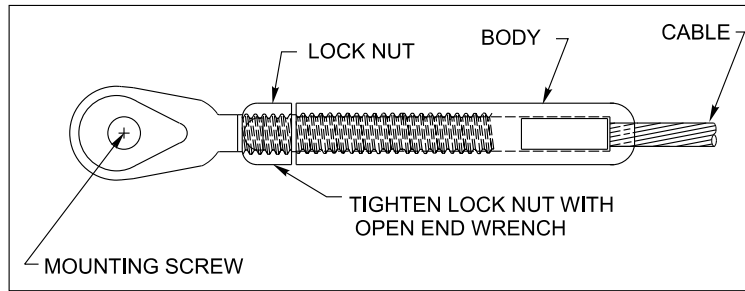

- On all installations, tighten the lock nut against the body of the fitting with an open end wrench.**

NOTE: In areas prone to tampering, the use of permanent setting thread sealant is recommended for mounting screws and lock nuts.

F. Tensioning cables

NOTE: Tension in sequence, beginning with the outside cables and moving from side to side toward the center (see Figure V below).

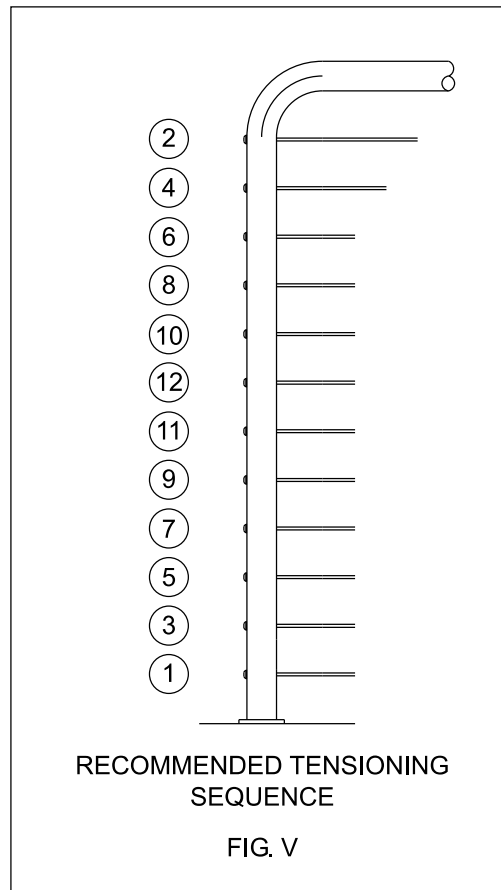

IG-14
4/1/15

Ultra-tec[®]
CABLE RAILING INFILL

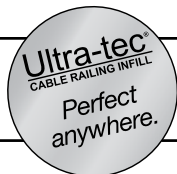

1-800-851-2961 ■ **775-885-1443** ■ **Fax 775-885-2734**
52 Heppner Drive ■ Carson City, NV 89706
E-mail: info@ultra-tec.com Website: www.ultra-tec.com

Wood Railings—Mounting Alternatives

The following illustrations demonstrate how the hardware can be used on a single corner post. Not all possible hardware combinations are shown. If the hardware and cable run all the way through the post in one direction, you will need to use a hanger bolt end or hardware that is mounted to a lag for the perpendicular direction.

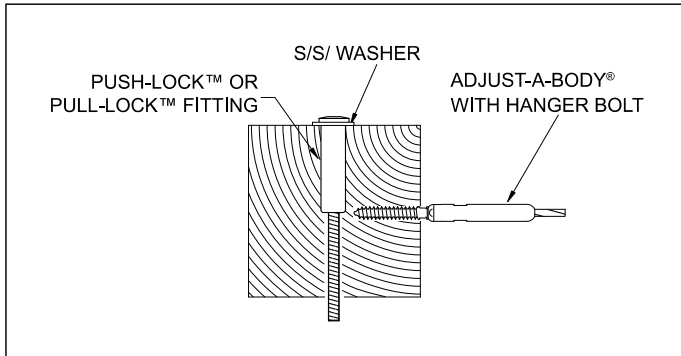
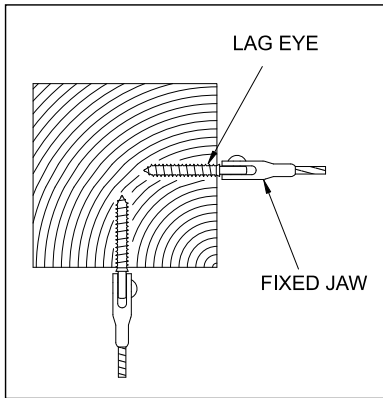
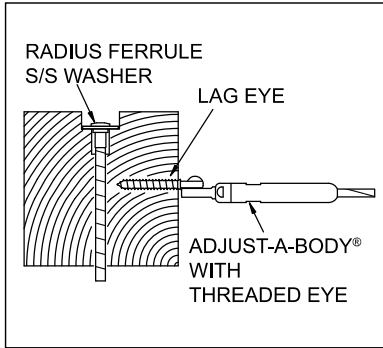
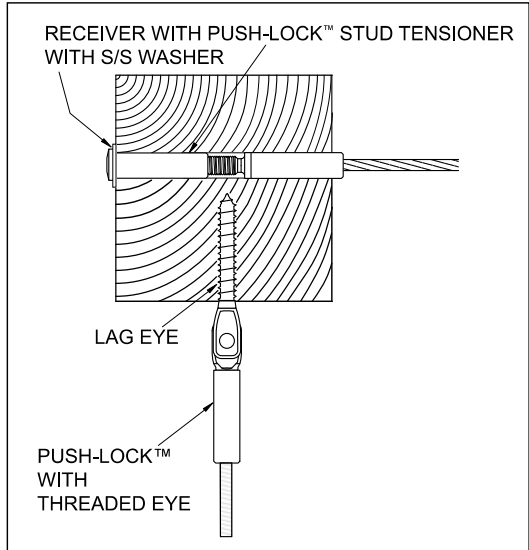
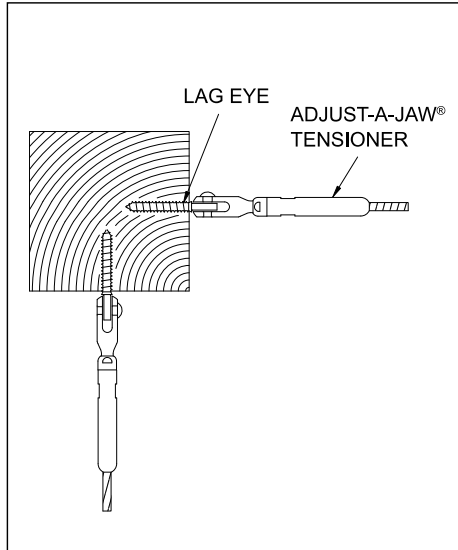
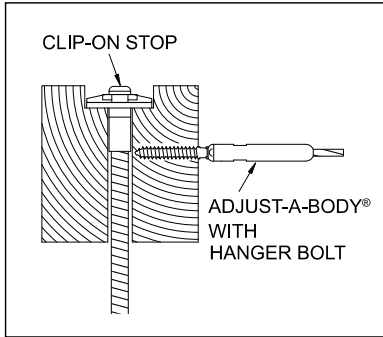
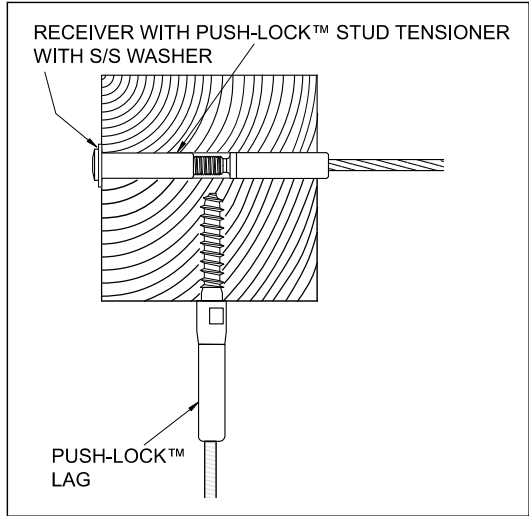
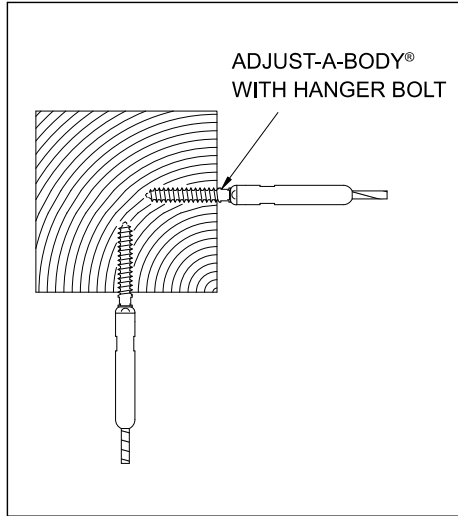
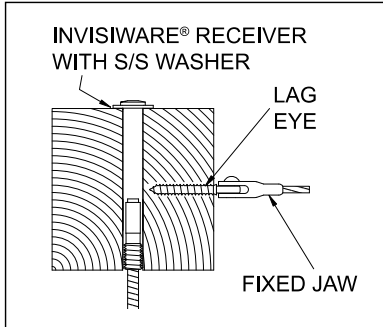

IG-15
4/15

Wood Railings—Mounting Alternatives (Continued)

Drilling Holes in End Posts for Cable Mounting Hardware

Where hardware that requires mounting with lag fittings is being used, drill holes in the end posts using the drill size shown on the following chart and screw lags into the holes. The Fixed Jaws, Adjust-A-Jaw and Adjust-A-Body with Threaded Eye tensioners, or Push-Lock Lags and Push-Lock with Threaded Eyes will be mounted to the lags.

CABLE SIZE	USING LAG PART NO.	USE DRILL SIZE*
1/8"	LE-6, PL-L4	9/32"
3/16"		
1/4"	LE-8	3/8"

**Due to the differences in different types of woods, slightly smaller or larger holes may be required for your particular application.*

Where tensioners with Hanger Bolts are being used, drill holes in the end posts using the drill size shown on the following chart and screw the Hanger Bolt into the holes. The body of the fitting will be mounted to the Hanger Bolt (see "Installing Cable," pages IG-4 through IG-14).

CABLE SIZE	USING PART NO.	USE DRILL SIZE
1/8"	A-JB6 A-JB6-L	If soft wood (Common Redwood), 7/32" drill bit
3/16"	PL-TB-HB-4/6 PL-TB-HBL-4/6	If hard wood (Common Douglas Fir), 15/64" drill bit
1/4"	A-JB8	3/8"

Drilling Holes in Intermediate Posts and Cable Braces

Cable Size	Hole Diameter Where Studs/Ferrules are Swaged in the Field or Swageless Fittings are Put on the Cables	Hole Diameter Using Push-Lock™ or Pull-Lock™ Fittings	Hole Diameter Where Cables Supplied by Factory with Fittings Swaged on Both Ends of Cable	
			Using Threaded Studs	Using Ferrules for Clip-on Fixed Jaws or Using Clip-on Stop
1/8"	5/32"	5/32"	11/32"	17/64"
3/16"	7/32"	7/32"	11/32"	17/64"
1/4"	9/32"	NA	15/32"	25/64"

IG-16
4/1/15

Ultra-tec[®]
CABLE RAILING INFILL

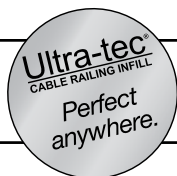

1-800-851-2961 ■ **775-885-1443** ■ **Fax 775-885-2734**
52 Heppner Drive ■ Carson City, NV 89706
E-mail: info@ultra-tec.com Website: www.ultra-tec.com

Wood Railings—Mounting Alternatives (Continued)

Options for mounting hardware in wood posts. Drill your holes using sizes shown in the chart below.

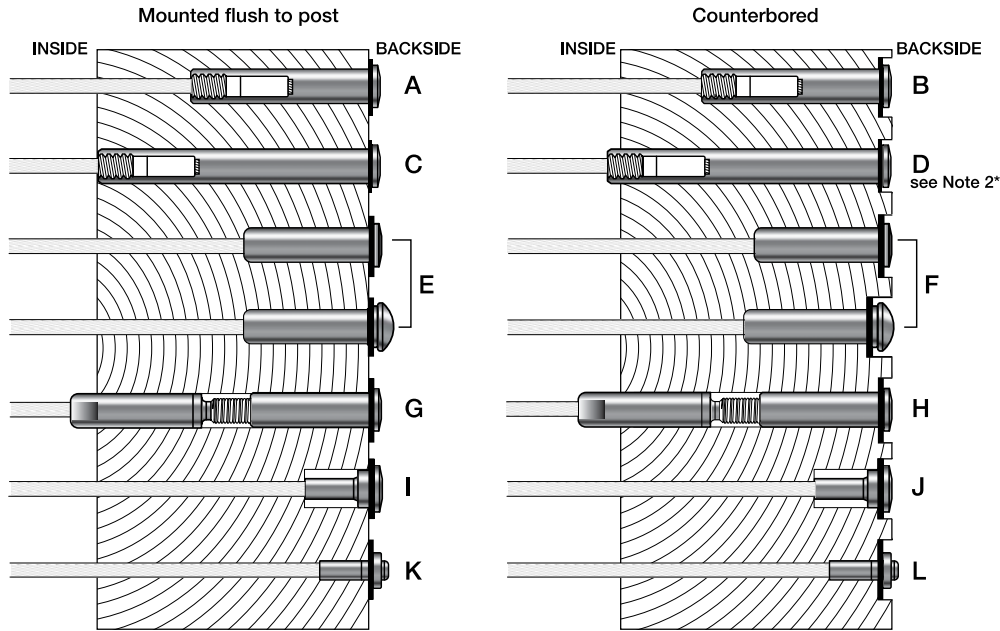

Mounting Option	Cable Dia.	Drill-through Hole for Cable, Threaded Stud, or Clip-on Stop	Drill Hole for Fitting (Receiver, Radius Ferrule, Push-Lock™, or Pull-Lock™ see Note 1*)	Use S/S S.A.E. Flat Washer	Counterbore Min. Dia. Hole for S.A.E. Flat Washer or Clip-on Stop Washer
A & B Invisiware® Receiver under 3.5" long	1/8"	11/32"	29/64"	7/16"	15/16"
	3/16"				
	1/4"	15/32"	15/32"	1/2"	1-3/32"
C & D Invisiware® Receiver 3.5" long (Part No. R-6-62)	1/8"	N.A.	29/64" see Note 2*	7/16"	15/16" see Note 2*
	3/16"				
E & F Push-Lock™ or Pull-Lock™ Fitting	1/8"	5/32"	29/64"	7/16"	15/16"
	3/16"				
G & H Receiver with Push-Lock™ Stud	1/8"	5/32"	29/64"	7/16"	15/16"
	3/16"				
I & J Radius Ferrule	1/8"	5/32"	29/64"	7/16"	15/16"
	3/16"	7/32"			
	1/4"	9/32"	35/64"	1/2"	1-3/32"
K & L Clip-on Stop	1/8"	17/64"	N.A.	N.A.	15/16"
	3/16"				

***Note 1:** Hole depth will depend upon the mounting option you choose and the length of the part you are using.

***Note 2:** If you are mounting a 3-1/2" long Invisiware Receiver (part no. R-6-62) in a standard 4x4 (3-1/2" x 3-1/2") post, you: 1) will drill your hole clear through the post, and 2) should NOT counterbore the hole if the cable run is on a severe pitch or stairway. If your end post is thicker than 3-1/2", then drill your holes using Mounting Options A & B.

IG-17
4/1/15

Ultra-tec®
CABLE RAILING INFILL

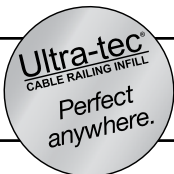

1-800-851-2961 ■ 775-885-1443 ■ Fax 775-885-2734
52 Heppner Drive ■ Carson City, NV 89706
E-mail: info@ultra-tec.com Website: www.ultra-tec.com

MEASURING AND INSTALLING CABLE

Vertical Railings

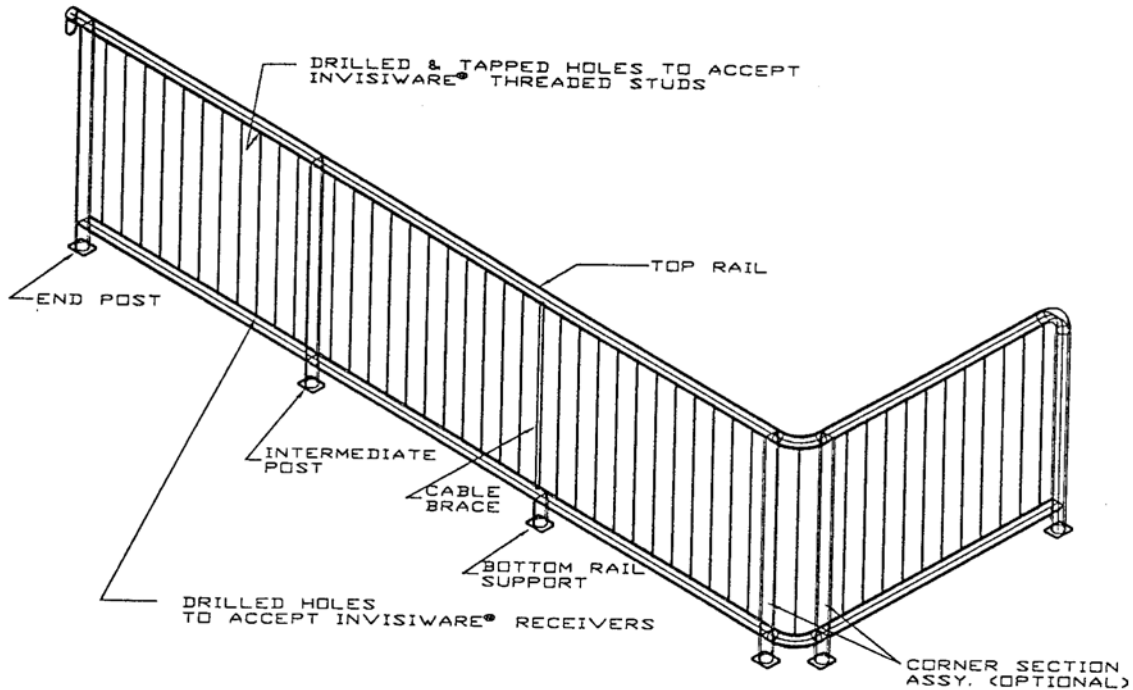

If you have ordered your cables cut to length from the factory, you can skip the steps indicated with * on measuring cable length and swaging fittings onto cable.

- A. *Measure the distance between the bottom of the top rail to the top of the bottom rail and add 2.187" (2-3/16").

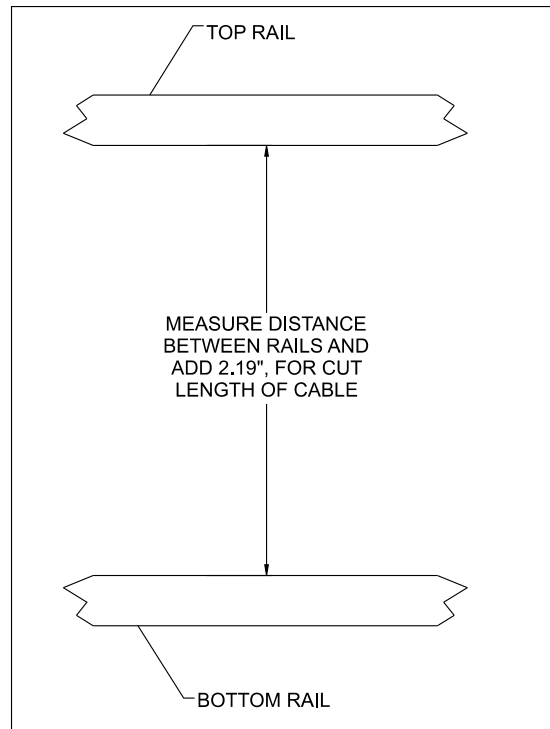

IG-18
4/1/15

Ultra-tec®
CABLE RAILING INFILL

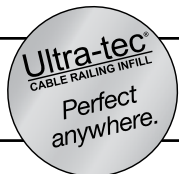

1-800-851-2961 ■ 775-885-1443 ■ Fax 775-885-2734
52 Heppner Drive ■ Carson City, NV 89706
E-mail: info@ultra-tec.com Website: www.ultra-tec.com

Measuring And Installing Cable—Vertical Railings (Continued)

- B. *Measure out the cable on a relatively clean surface** (see Figure C below). A lawn or swept concrete surface would be fine. Cut cable to the length determined in Step A on page IG-18, using cable cutter.

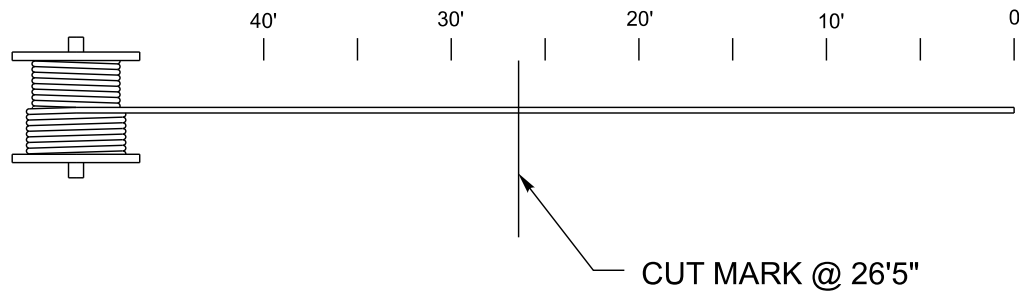
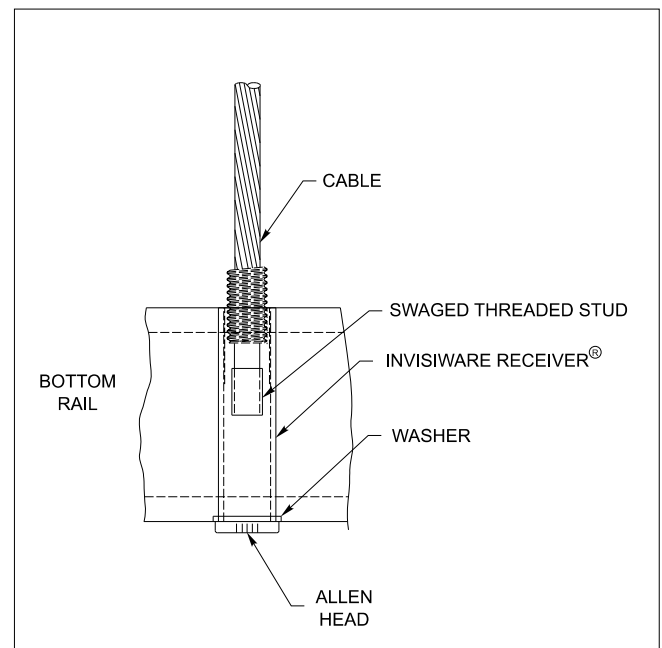

FIG. C

NOTE: Make sure you have a positive holding device at the zero end. Cutting the cables takes very little time. It is best to have one person stand at the zero mark while the other operates the cable cutter at the cut mark.

- C. *Swage a Stud onto each end of the cable** (see "Swaging Instructions," pages IG-20 to IG-23).
- D. Screw the swaged Stud on one end of the cable into the threads in the top rail, until the threads on the Stud are not showing.**
- E. Slide the washer over the body of the Invisiware® Receiver, then feed the Receiver through the hole in the bottom of the bottom rail. Screw the Receiver onto the threaded Stud.**
- F. Repeat above steps for each cable to be installed between posts.**



- G. Tension the cables** (to between 300 and 400 lbs.) by holding the cable (using cable gripping pliers) closely above the Stud in the bottom rail. Turn the Receiver clockwise with an Allen wrench from underneath the bottom rail. First, tension the outside cables for each section between posts/and or cable braces. Then, tension the rest of the cables in sequence, by alternating from one end to the other, working toward the center away from the posts/braces. Tension each section this way. (Since vertical railing is braced differently than horizontal railing, the installation sequence is less critical. It can be installed from the post/braces in , from the center out, section by section, or over the whole span of the railing.)

SWAGING INSTRUCTIONS

Before you begin swaging

NOTE: If you are using coated cable, be sure to strip the coating from the end of the cable before swaging.

If you are using the Adjust-A-Jaw or Adjust-A-Body type tensioner or Ultra-tec Fixed Jaw fitting, make sure the cable has been inserted through the body of the fitting prior to swaging the ferrule onto the cable. See illustrations below.

Adjust-A-Jaw or Adjust-A-Body Tensioner

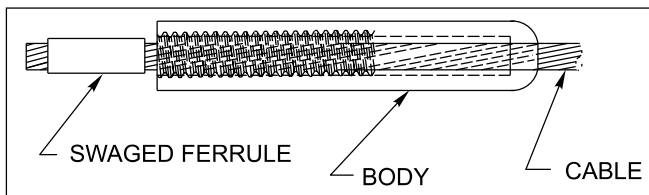

Ultra-tec Fixed Jaw

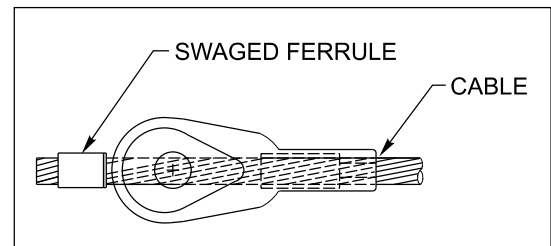

If you are using the Invisiware Receiver or Welded Receiver (threaded receiver inside post), the Stud will be swaged onto the end of the cable and will install directly into the fitting.

If you are using the Invisiware Radius Ferrule or Clip-on Stop, the fitting will be swaged onto the end of the cable and no further operation will be required.

NOTE: *Swage the fitting on one end of the cable only*, before stringing cables through posts and braces. Where only one end of the cable has an adjusting fitting (Invisiware Receiver or Adjust-A-Jaw or Adjust-A-Body type tensioner), we recommend that you *swage the unadjusting end first* and the adjusting end last (after the cables have been strung).

Swaging

IMPORTANT: NEVER CUT OR OTHERWISE TAMPER WITH ANY SWAGED FITTING.

A. If you are using any fittings other than Radius Ferrules or Clip-on Stops, position the Ferrule or (threaded) Stud onto the Cable as shown in Figure D below.

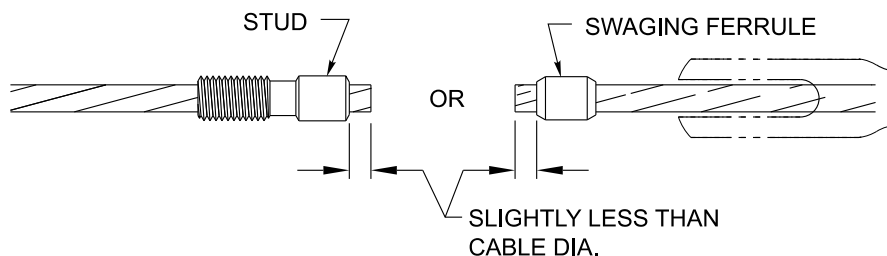
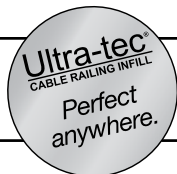

FIG. D

IG-20
4/1/15

Ultra-tec[®]
CABLE RAILING INFILL



1-800-851-2961 ■ 775-885-1443 ■ Fax 775-885-2734
52 Heppner Drive ■ Carson City, NV 89706
E-mail: info@ultra-tec.com Website: www.ultra-tec.com

Swaging (Continued)

If you are using **Radius Ferrules** or **Clip-on Stops**, slide the Cable into the open end of the fitting until it stops (see Figures E and I below).

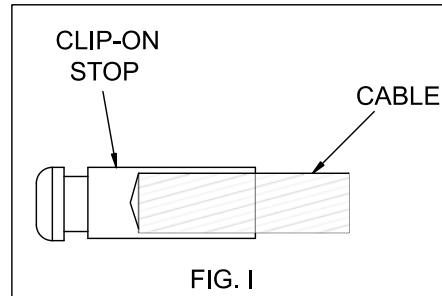
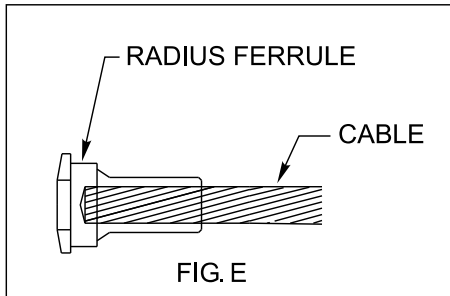

B. Place Ferrule, Radius Ferrule, or Stud into open Swager dies.

Use the Ultra-tec Model 610 Portable Swager for 1/8" and 3/16" diameter cable with S-4 and S-6 Studs, RF-4 and RF-6 Radius Ferrules, and F-4 & F-6 Ferrules. Use the Ultra-tec Model 650 Portable Swager for all sizes of cable.



**610 Portable Swager for use with
1/8" and 3/16" diameter cable.**



**650 Portable Swager for use with
all sizes of cable.**

Swaging (Continued)

Make sure the die size you use in the swager is the one marked for the diameter of the cable onto which the fitting is being swaged.

For Ferrules

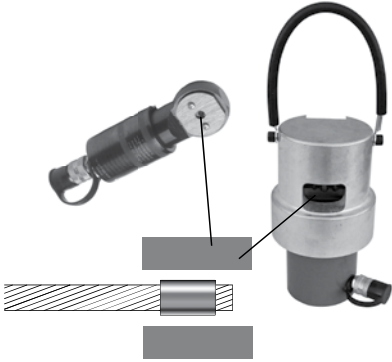

For Radius Ferrules

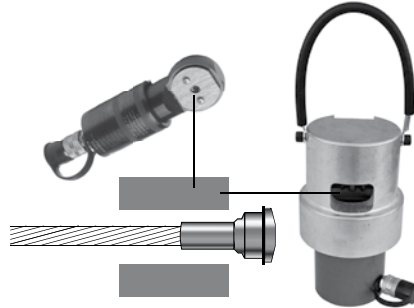

For Studs

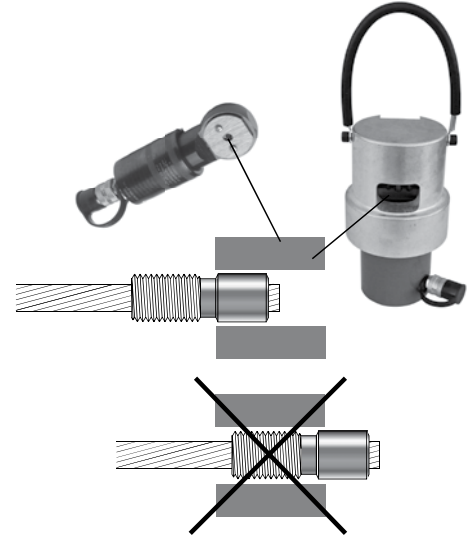

When swaging the threaded stud, make sure the threads are not in the swager.

- C. Depress the foot pedal to introduce pressure into the swaging tool.** Do not let the dies close all the way on the first cycle.
- D. Release the foot pedal and apply foot pressure in the opposite direction** (this will re-open the dies). **Turn the fitting 45 degrees and repeat Step C. Do not let the die close all the way.**
- E. Turning the fitting 45 degrees each time, swage the fitting, letting the die close completely 4 to 8 more times.**

NOTE: When swaging a Stud, the non-threaded end of the Stud should face the end of the cable. When properly swaged, the Ferrule will look like Figure H and the Stud will look like Figure J below after swaging and will slide easily into the body of the fitting.

Ferrule



FIG. H

Stud

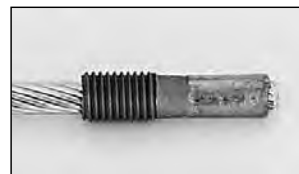
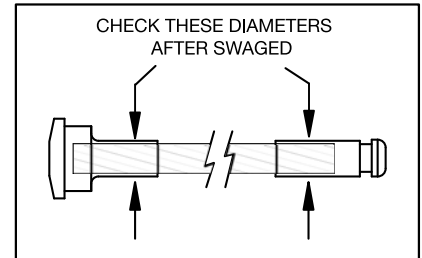

FIG. J

Swaging (Continued)

For the Radius Ferrule or Clip-on Stop, use the appropriate "GO" gauge. The swaged Radius Ferrule should fit the slot in the "GO" gauge when properly swaged. If you do not have a "GO" gauge, use calipers to check diameter of the swaged portion of the Radius Ferrule. See the chart below for the correct diameter of the Radius Ferrule after it has been swaged.

Radius Ferrule	Clip-on Stop	For Cable Diameter	Dia. of Swaged Portion of Fitting Should Be
RF-4 or RF-6	COS-4 or COS-6	1/8" or 3/16"	.250" Max.
RF-8	N.A.	1/4"	.375" Max.
RF-10 or RF-12	N.A.	5/16" or 3/8"	.500" Max.



Ultra-tec® "Clip-on" Fixed Jaw Installation Instructions

1. Slide Swaged Cable Ferrule end through throat of Fixed Jaw.

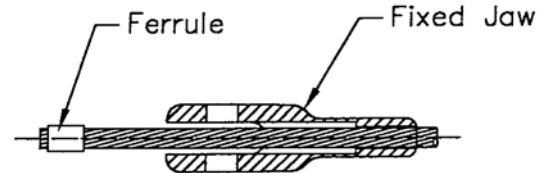

2. Grasp top of Clip with pliers, and force clip over cable immediately behind Ferrule.

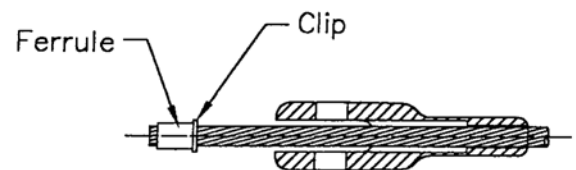

3. Pull cable back through throat of Fixed Jaw until it stops. Ferrule is captured inside Fixed Jaw.

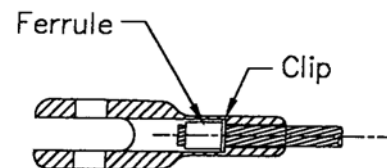

IG-23
4/1/15

Ultra-tec®
CABLE RAILING INFILL

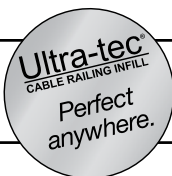

1-800-851-2961 ■ 775-885-1443 ■ Fax 775-885-2734
52 Heppner Drive ■ Carson City, NV 89706
E-mail: info@ultra-tec.com Website: www.ultra-tec.com

Using Invisiware Receivers on Stairways

The following instructions illustrate how you can use an Invisiware Receiver and Stud on stairway end posts, without having to drill holes on an angle.

Section A. This section applies if you are installing Invisiware Receivers on both ends of your cable run.

If the cables are supplied with studs on each end, you can disregard steps 1, 4 and 5 below.

1. **Swage the stud** onto the end of the cable to be installed at the bottom of the stairway. See the "Swaging Instructions" on pages IG-21 to IG-24.

2. **Grip the cable with cable grip locking pliers** approximately 1/8" from the swaged stud. Screw the Receiver onto the stud for leverage, and bend the cable by hand to the approximate angle desired. This bend does not have to be precise.

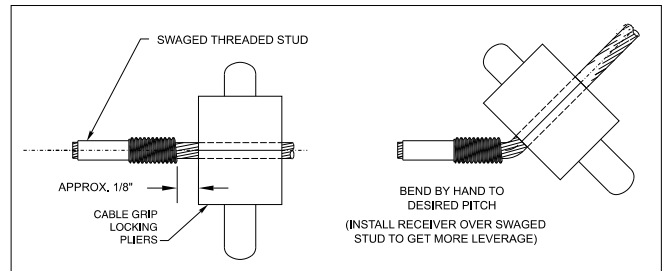

3. **Install the Receiver** in the post at the bottom of the stairway, following the instructions in the "Installing Cable" section for installing Invisiware Receiver at Post A. Make sure the stud is flush with the outside wall of the post. See illustration at right.

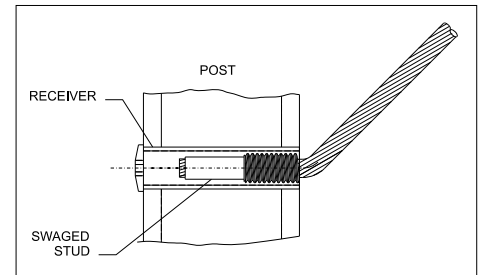

4. **Pull the cable** to the hole in the post at the top of the stairway where the Receiver will be installed on the other end of the cable. Mark the cable at the center point of the hole. See illustration at right.

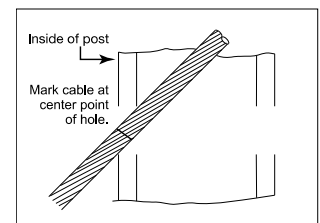

5. **Swage the Stud** onto the end of the cable with the threaded end at the mark made in Step 4. See "Swaging Instructions" on pages IG-21 to IG-24, and the illustration at right. Cut off any excess cable, leaving a small "tail" out of the end of the Stud.



6. **Bend the cable** to the approximate angle desired as done in Step 2 above. Make sure bends are on the same plane.

7. **Install the Receiver** in the post at the top of the stairway, following the instructions in the "Installing Cable" section of this Installation Guide for installing Invisiware® Receivers at Post B. When tensioned, the cables will self-align at each end post.

IG-24
4/1/15

Ultra-tec
CABLE RAILING INFILL

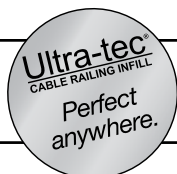

1-800-851-2961 ■ 775-885-1443 ■ Fax 775-885-2734
52 Heppner Drive ■ Carson City, NV 89706
E-mail: info@ultra-tec.com Website: www.ultra-tec.com

Using Invisiware Receiver on Stairways (Continued)

Section B. This section applies if you are installing Invisiware Receivers on one end and another type of fitting on the other end of your cable run. If the cables are supplied with studs on the Invisiware® Receiver ends, then you can disregard steps 2 and 3 below.

1. Install the fitting on the non-Receiver end of the run first.

See the instructions for that fitting in the "Installing Cable" on pages IG-4 to IG-14.

2. Pull the cable to the hole in the post at the Receiver end of the run.

Mark the cable at the center point of the hole.
See illustration at right.

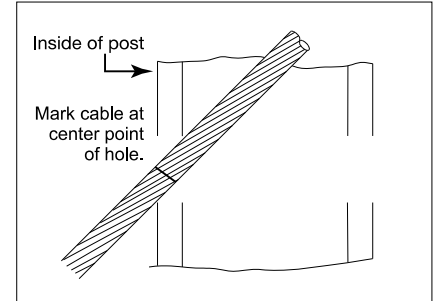

3. Swage the Stud onto the end of the cable with the threaded

end at the mark made in Step 2. See "Swaging Instructions" on pages IG-21 to IG-24, and the illustration at right. Cut off any excess cable, leaving a small "tail" out of the end of the stud.

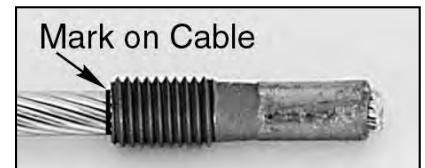

4. Grip the cable with cable grip locking pliers

approximately 1/8" from the swaged stud. Screw the Receiver onto the stud for leverage, and bend the cable by hand to the approximate angle desired. This bend does not have to be precise.

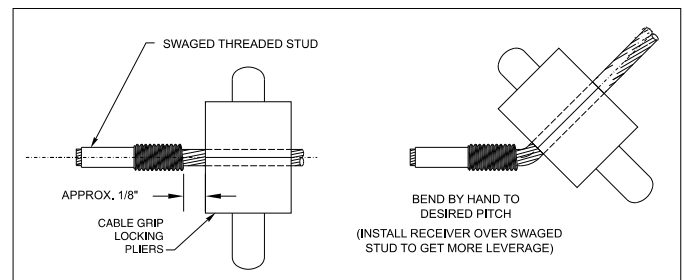

5. Install the Receiver in the post, following the

instructions for installing Invisiware® Receivers at Post B in the "Installing Cable" on pages IG-4 to IG-14. When tensioned, the cables will self-align with the fitting at the other end of the cable run.

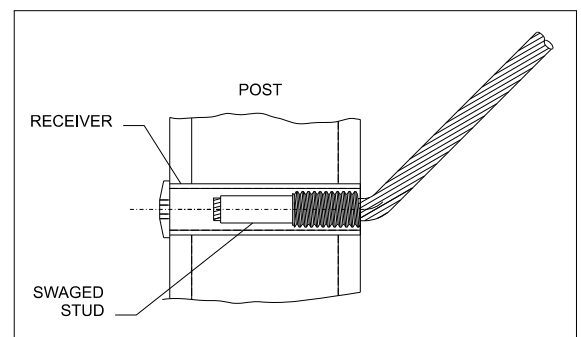

Ultra-tec "Clip-on" Stop Installation Instructions

**Feed cables through intermediate posts and install "Clip-on" Stop first,
before installing tensioning end of cable.**

1. Drill 17/64" (.266") hole all the way through the post.
2. If you wish to countersink the Stop in a wood post, then drill a 15/16" (.938") hole to a depth of 3/16" in the back side of the post.

If you are using steel pipe, see Fabrication Instructions. There should be a 17/32" (.531") hole counterbored to a .100" depth, so the full diameter of the washer will rest on a flat surface in the pipe.

3. From the inside side of the post, slide the cable through the hole, Stop end first, and out the back side of the post.

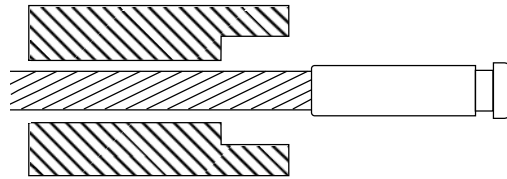

4. Slide the washer over body of the Stop.

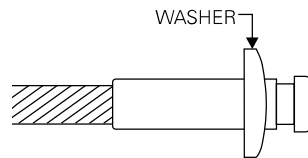

5. Force the Clip into the slot in the Stop, and press it in by hand. Press Clip with pliers to secure it in slot.

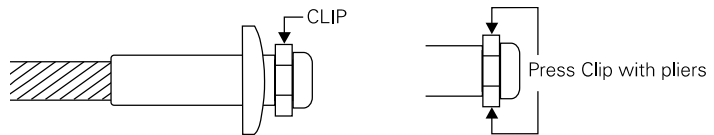

6. Pull cable back through the hole, until the washer stops against the post, with the Clip resting in the recess of the washer.

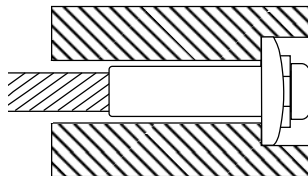

7. Install the hardware on the post at the tensioning end of the cable.

IG-26
4/1/15

Ultra-tec[®]
CABLE RAILING INFILL

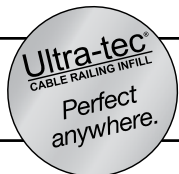

1-800-851-2961 ■ **775-885-1443** ■ **Fax 775-885-2734**
52 Heppner Drive ■ Carson City, NV 89706
E-mail: info@ultra-tec.com Website: www.ultra-tec.com

Push-Lock Stop-End (non-tensioning) Fittings Installation Instructions

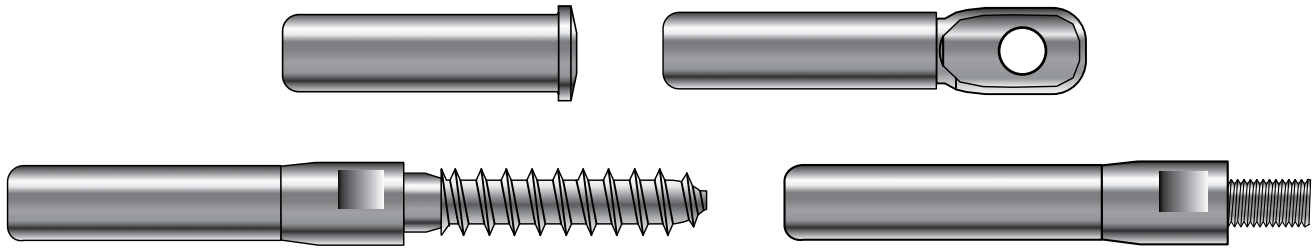

Install tensioning end of run to one end post and run cables through intermediate posts, before installing Push-Lock fitting.

1. Make sure the holes are drilled properly in the end post where you will be installing the Push-Lock fitting.

If you are installing the Push-Lock fittings in a metal railing, see *Metal Railings/Hardware Mounting Holes/Boring Guide* for boring instructions for your end post.

If you are using wood end posts, see “Wood Railings-Mounting Alternatives” on pages IG-16 and IG-17 for hole sizes and depths.

2. Slip the washer over the body of the fitting (7/16 SAE washer for wood posts, black Delrin® washer for metal posts), then slide the Push-Lock fitting into the hole in your end post with the hole in the fitting facing the inside (cable side) of the post.

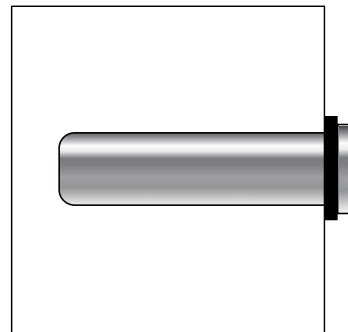

- 2A. If you are using the Push-Lock with Threaded Eye, attach the threaded tab or lag eye to the end post and connect the Push-Lock with Threaded Eye with a screw.

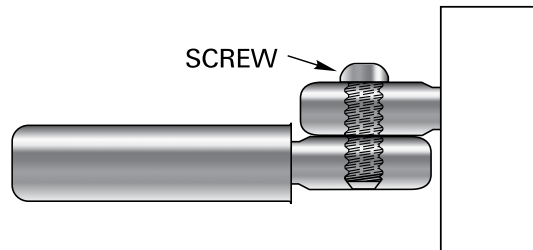

Push-Lock Fittings (Continued)

2B. If you are using a Push-Lock Lag, use a hex wrench to install the lag section of the fitting into your pre-drilled hole.

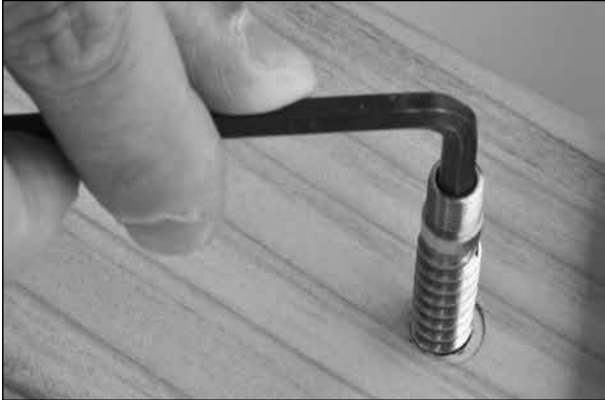

Then thread the Push-Lock coupler onto the lag.



Make sure the post side of the Push-Lock Lag is flush against the post.

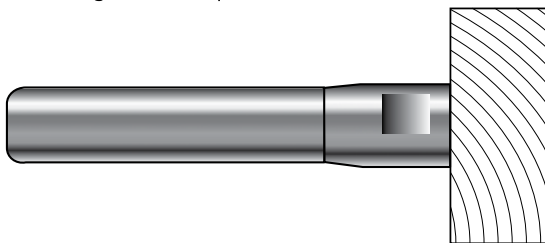

2C. If you are using a Push-Lock Threaded Bolt, hand-turn the fitting into your post hole pre-drilled and tapped to 5/16-24.



Then tighten with a 7/16" (or crescent) wrench.



Make sure the post side of the Push-Lock Threaded Bolt is flush against the post.

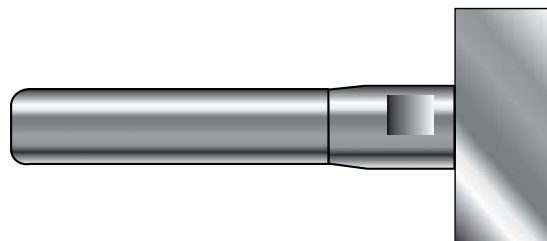

IG-28
4/1/15

Ultra-tec[®]
CABLE RAILING INFILL

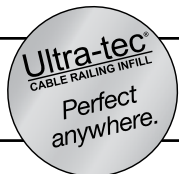

1-800-851-2961 ■ 775-885-1443 ■ Fax 775-885-2734
52 Heppner Drive ■ Carson City, NV 89706
E-mail: info@ultra-tec.com Website: www.ultra-tec.com

Push-Lock Fittings (Continued)

- Pull the cable tight and mark the cable at a point 1-3/16" from the end of the fitting opposite the eye/lag. Cut the cable at the mark, using a cable cutter.

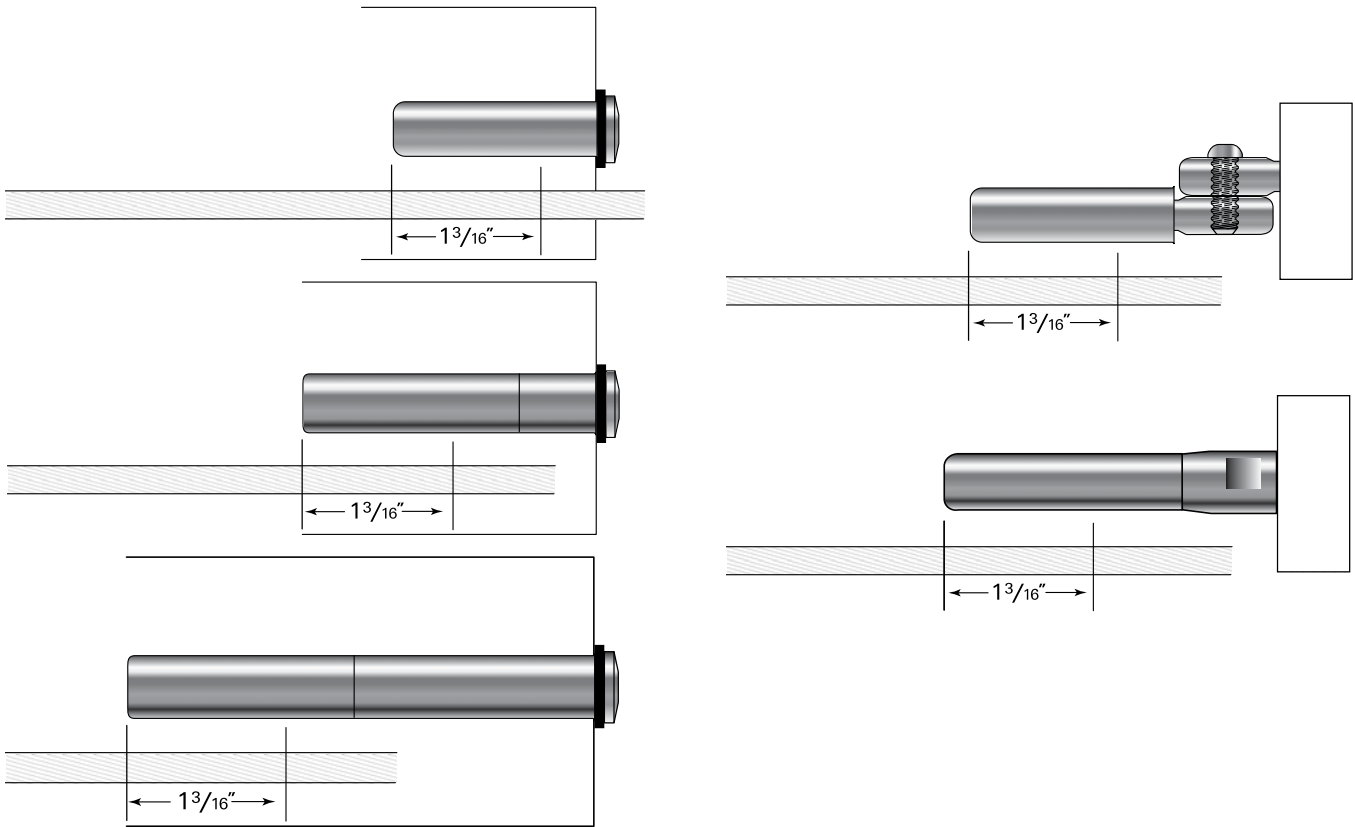

- Detach the tensioning device from the cable at the other end of the run to allow cable slack so you can perform the next step.
- Push the cable into the hole in the fitting as far as it will go (approximately 1-1/16"). Twist the cable in the right-hand direction as you push it into the fitting. You will feel it slide through the jaws inside the stud. (If applicable, you will receive a PL-Key with your order. This may aid in your cable installation. Please see instructions for use of the PL-Key at the end of this section).

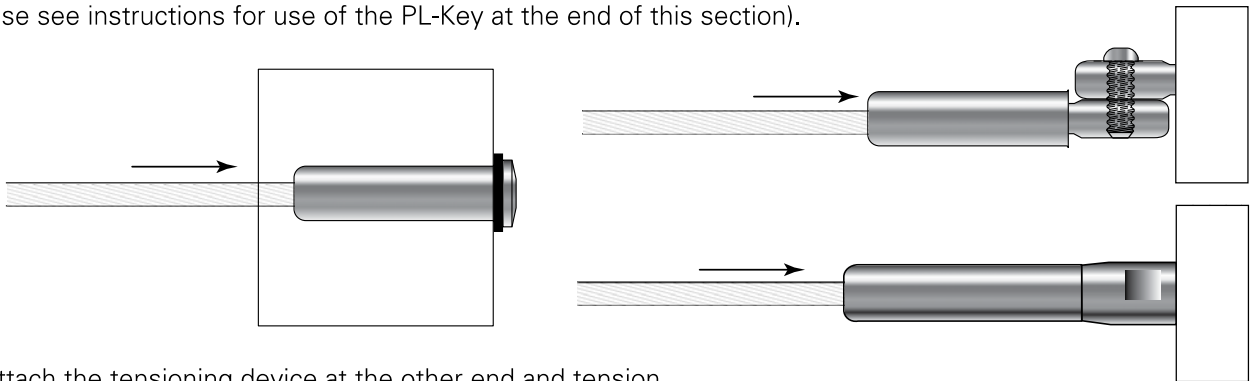

- Reattach the tensioning device at the other end and tension following the separate instructions for the tensioner you're using.

IG-29
4/1/15

Ultra-tec®
CABLE RAILING INFILL

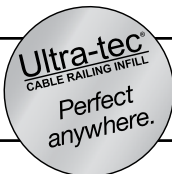

1-800-851-2961 ■ 775-885-1443 ■ Fax 775-885-2734
52 Heppner Drive ■ Carson City, NV 89706
E-mail: info@ultra-tec.com Website: www.ultra-tec.com

Pull-Lock Stop-End (non-tensioning) Fittings Installation Instructions

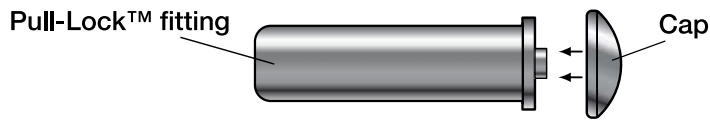

Make sure the holes are drilled properly in the posts where you will be installing your fittings.

If you are installing the fittings in a metal railing,

see *Metal Railings/Hardware Mounting Holes/Boring Guide* for boring instructions.

If you are using wood end posts,

see "Wood Railings-Mounting Alternatives" section in this guide (pages IG-16 and IG-17) for hole sizes.

For wood, first drill a pilot hole through the post that is 1/16" larger than the diameter of the cable you are using. (It is best to drill the pilot hole from one side about half-way through the post and then drill from the other side to complete the hole.) Then drill a 29/64" hole from the back side of the post at least 1-3/4" deep (deeper if you are counterboring for the over-sized washer).

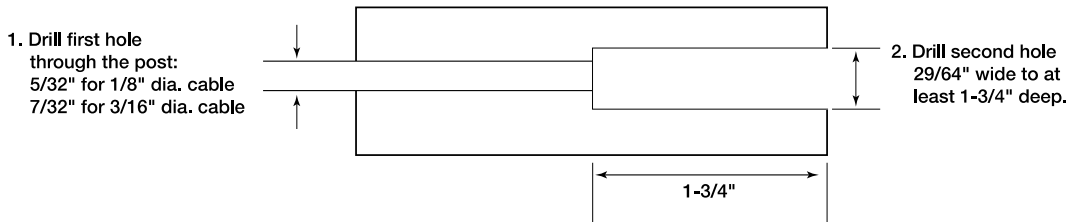

- Following the instructions elsewhere in this guide for the tensioning device you will be installing on one end of the cable run, install the tensioning device to your end post on one end of the cable run first (Post A below).

Post A



Tensioning Device

Post B



Pull-Lock™ Fitting

- Run the cable through the intermediate posts (if any) and through Post B where you will be installing the Pull-Lock™ fittings.

Post A



Tensioning Device

Post B



Pull-Lock™ Fitting

- Cut the cable with a cable cutter, leaving enough cable extending out from the back side of the post to be able to grasp the cable firmly with your hand (6" or more).

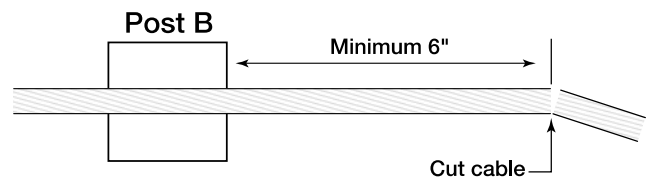

IG-30

4/1/15

Ultra-tec
CABLE RAILING INFILL

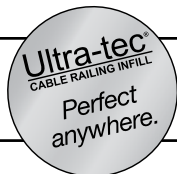

1-800-851-2961 ■ 775-885-1443 ■ Fax 775-885-2734

52 Heppner Drive ■ Carson City, NV 89706

E-mail: info@ultra-tec.com Website: www.ultra-tec.com

Pull-Lock Stop-End Fittings (Continued)

4. Slip the washer over the body of the Pull-Lock fitting (7/16SAE washer for wood posts, black Delrin® washer for metal posts).

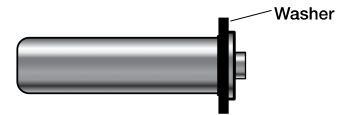

5. Push the cable into the hole in the front of the Pull-Lock fitting and pull the cable through the fitting. Twist the cable in the right-hand direction as you push it into the fitting. Then slide the fitting along the cable and up to the back side of the post.

(If applicable, you will receive a PL-Key with your order. This may aid in your cable installation. Please see instructions for use of the PL-Key at the end of this section).

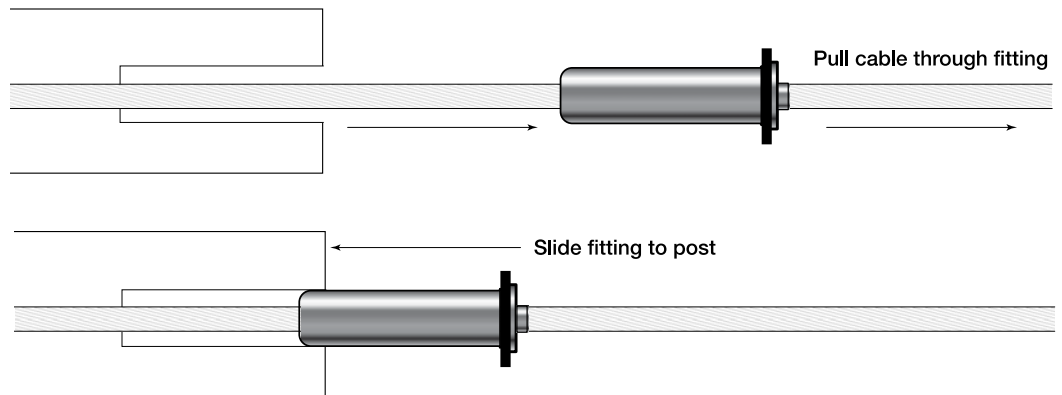

6. Hold the cable with one hand and slide the Pull-Lock fitting into the hole in the post. Press on the back of the Pull-Lock fitting to hold it securely in the post and pull the cable through the fitting until it is as tight as you can make it.

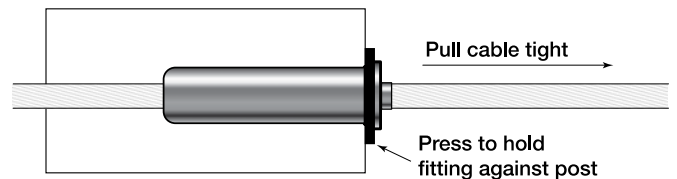

7. Cut the cable flush with the hole in the back of the Pull-Lock fitting, using a cut-off wheel (see CUT-OFF KIT in our product catalog).

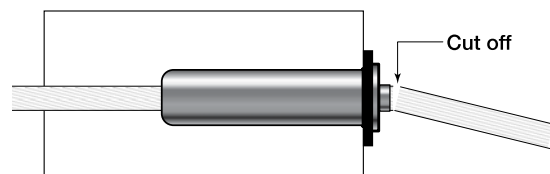

8. Press the cap onto the lip of the Pull-Lock fitting.

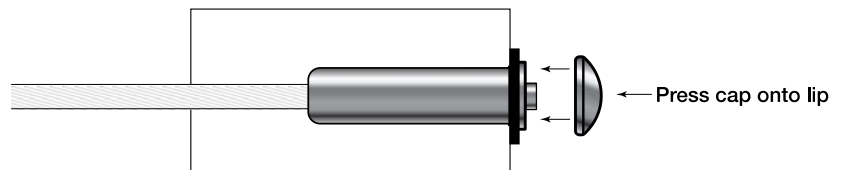

9. Tension the cable with the tensioner installed on the end post (Post A) at the other end of the cable run, after all the fittings have been installed in both end posts.

Receiver with Push-Lock™ Stud Installation Instructions



Make sure the holes are drilled properly in the posts where you will be installing your fittings.

If you are installing the fittings in a metal railing,

see *Metal Railings/Hardware Mounting Holes/Boring Guide* for boring instructions.

If you are using wood end posts, see "Wood Railings-Mounting Alternatives" section in this guide (pages IG-16 and IG-17) for hole sizes.

For wood posts, drill a 29/64" hole through the post. (It's best to drill about half-way from one side, then drill from the other side to complete the hole. You may want to drill a pilot hole with a smaller bit first.)

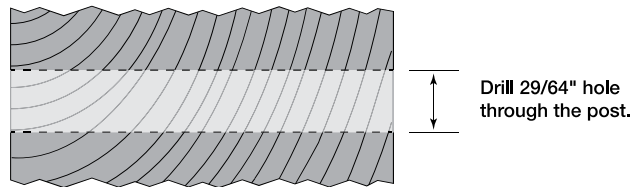

Section A. Instructions in this section apply if you are using a Receiver with Push-Lock™ Stud on one end of your cable run and any device OTHER THAN a Pull-Lock™ fitting on the other end. If you are using a Pull-Lock™ fitting on the other end, see Section B, page IG-35.

Step A. Install other fitting on the first end post (Post A below).

1. Install the fitting you will be using in the end post opposite the end in which you will be installing the Receiver with Push-LockStuds first (Post A).

Post A



Other Fitting

Post B



Receiver with Push-Lock™ Stud

If you will be using another Receiver with Push-Lock Stud at Post A, see step 1A below.

For all other fittings, follow the instructions for installing that device found in this *Installation Guide*, and then proceed to Step B on the following page.

- 1A. If you are installing another Receiver with Push-Lock™ Stud on the other end of your cable run (Post A), install that tensioner in Post A, as follows, before you proceed with step B on next page.

- 1) Turn the Receiver onto the threads of the Push-Lock™ Stud at least 6 turns.

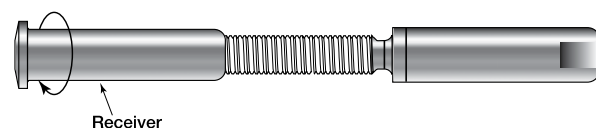

IG-32
4/1/15

Ultra-tec®
CABLE RAILING INFILL

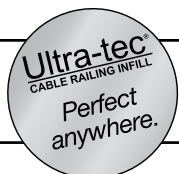

1-800-851-2961 ■ 775-885-1443 ■ Fax 775-885-2734
52 Heppner Drive ■ Carson City, NV 89706
E-mail: info@ultra-tec.com Website: www.ultra-tec.com

Receiver with Push-Lock Stud (Continued)

2) Slip the washer over the body of the Receiver (7/16SAE washer for wood posts, black Delrin® washer for metal posts), then slide the Receiver with Push-Lock Stud into the hole in your post with the Receiver cap end at the back side of the post.

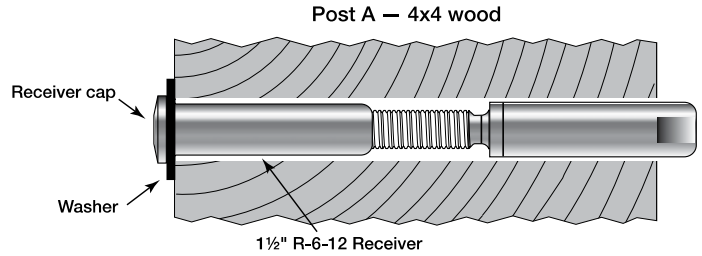

3) Push the cable into the hole in the fitting as far as it will go (approximately 1-1/16"). Twist the cable in the right-hand direction as you push it into the fitting. You will feel it slide through the jaws inside the stud. (If applicable, you will receive a PL-Key with your order. This may aid in your cable installation. Please see instructions for use of the PL-Key at the end of this section).

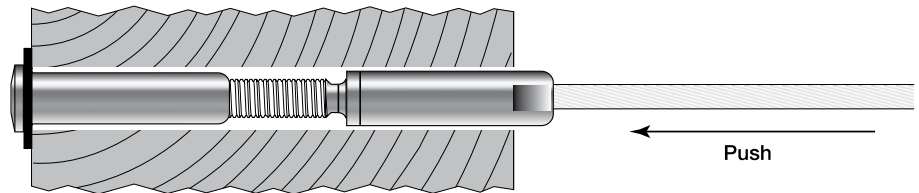

Step B. Install the Receiver with Push-Lock™ Stud on Post B.

1. Run the cable through the intermediate posts (if any) to Post B.



2. Turn the Receiver onto the threads of the Push-Lock™ Stud approximately 6 turns.

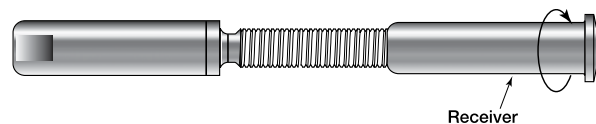

3. Slip the Washer over the body of the Receiver (7/16SAE washer for wood posts, black Delrin® washer for metal posts), then slide the Receiver with Push-Lock™ Stud into the hole in Post B with the Receiver cap resting against the back side of the post.

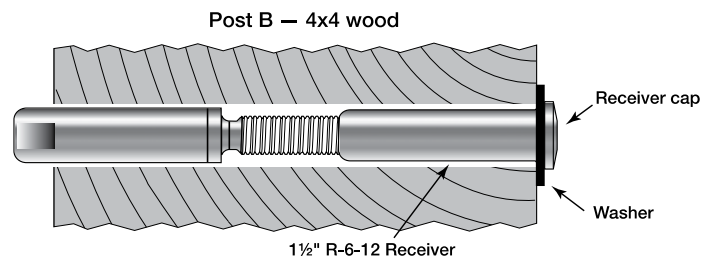

IG-33
4/1/15

Ultra-tec®
CABLE RAILING INFILL

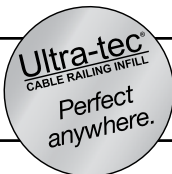

1-800-851-2961 ■ 775-885-1443 ■ Fax 775-885-2734
52 Heppner Drive ■ Carson City, NV 89706
E-mail: info@ultra-tec.com Website: www.ultra-tec.com

Receiver with Push-Lock Stud (Continued)

4. Pull the cable tight and mark the cable at a point $1\text{-}\frac{3}{16}$ " from the leading edge of the Push-Lock Stud. Cut the cable at the mark, using a cable cutter.

5. Push the cable into the hole in the stud as far as it will go (approximately $1\text{-}\frac{1}{16}$ "). Twist the cable in the right-hand direction as you push it into the fitting. You will feel it slide through the jaws inside the stud. (If applicable, you will receive a PL-Key with your order. This may aid in your cable installation. Please see instructions for use of the PL-Key at the end of this section).

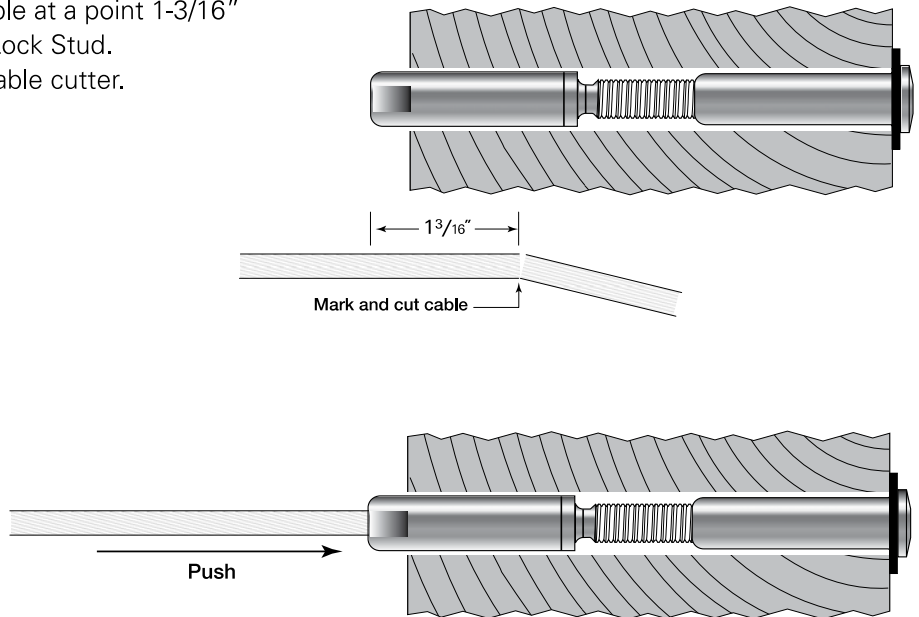

Step C. Tension the cable after all of the fittings have been installed on both end posts.

1. If there is a tensioning device on Post A, tension both ends. Follow the instructions for tensioning the device on Post A found in this guide and the instructions in No. 2 below for tensioning the Receiver with Push-Lock Studs in Post B.

Note: If you are using an Invisiware Receiver on the other end post A, tension the Receiver by turning it onto the threads of the Swaging Stud at least far enough that none of the threads on the stud are exposed when the cables are tight.

Note: If you are using Receivers with Push-Lock Studs on both ends (Post A and Post B), then follow No. 2 below for tensioning both ends.

2. Tension the cable. Grip the wrench flat on the end of the PushLock Stud with a $\frac{3}{8}$ " open-end wrench (to keep the cable from turning), then turn the Receiver with a $\frac{3}{16}$ " Allen wrench until the cables are tight.

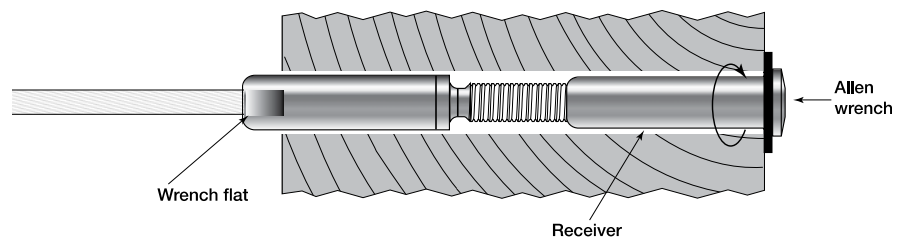

IG-34
4/1/15

Ultra-tec[®]
CABLE RAILING INFILL

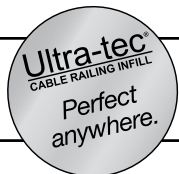

1-800-851-2961 ■ 775-885-1443 ■ Fax 775-885-2734
52 Heppner Drive ■ Carson City, NV 89706
E-mail: info@ultra-tec.com Website: www.ultra-tec.com

Receiver with Push-Lock Stud (Continued)

Section B. Instructions in this section apply if you are using a Receiver with Push-Lock Stud on one end of your cable run and a Pull-Lock fitting on the other end. For all other combinations, see Section A, pages IG-32 to IG-34.

Step A. Install the Receiver with Push-Lock Stud in the first end post (Post A below).

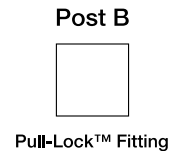
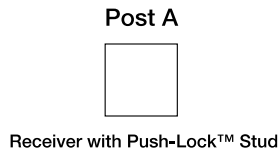

1. Turn the Receiver onto the threads of the Push-Lock Stud approximately 6 turns.

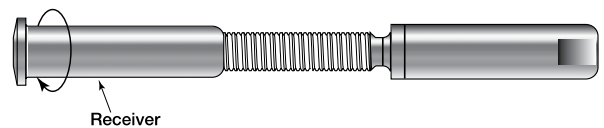

2. Slip the Washer over the body of the Receiver (7/16SAE washer for wood posts, black Delrin® washer for metal posts), then slide the Receiver with Push-Lock Stud into the hole in Post A, with the Receiver cap resting against the back side of the post.

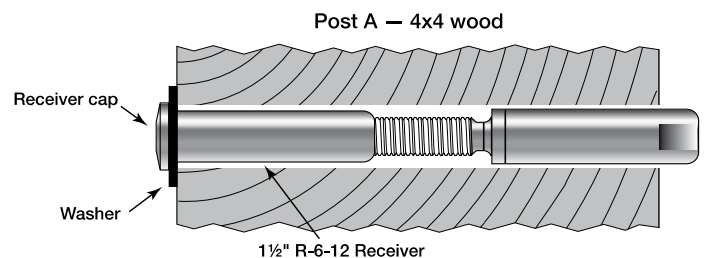

3. Push the cable into the hole in the stud as far as it will go (approximately 1-1/16"). Twist the cable in the right-hand direction as you push it into the fitting. You will feel it slide through the jaws inside the stud. (If applicable, you will receive a PL-Key with your order. This may aid in your cable installation. Please see instructions for use of the PL-Key at the end of this section).

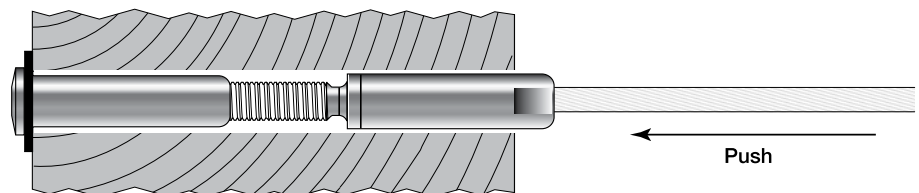

Receiver with Push-Lock Stud (Continued)

Step B. Install the Pull-Lock™ fitting on Post B.

1. Run the cable through your intermediate posts (if any) and through Post B where you will be installing the Pull-Lock fitting.

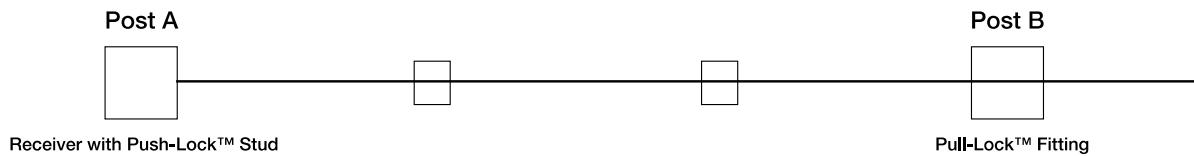

2. Cut the cable with a cable cutter, leaving enough cable extending out from the back side of the post to be able to grasp the cable firmly with your hand (6" or more).

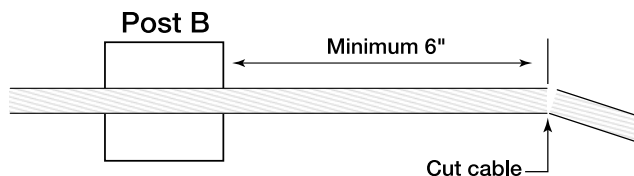

3. Slip the washer over the body of the Pull-Lock fitting (7/16SAE washer for wood posts, black Delrin® washer for metal posts).



4. Push the cable into the hole in the front of the Pull-Lock fitting and pull the cable through the fitting. Twist the cable in the right-hand direction as you push it into the fitting. Then slide the fitting along the cable and up to the back side of the post. (If applicable, you will receive a PL-Key with your order. This may aid in your cable installation. Please see instructions for use of the PL-Key at the end of this section).

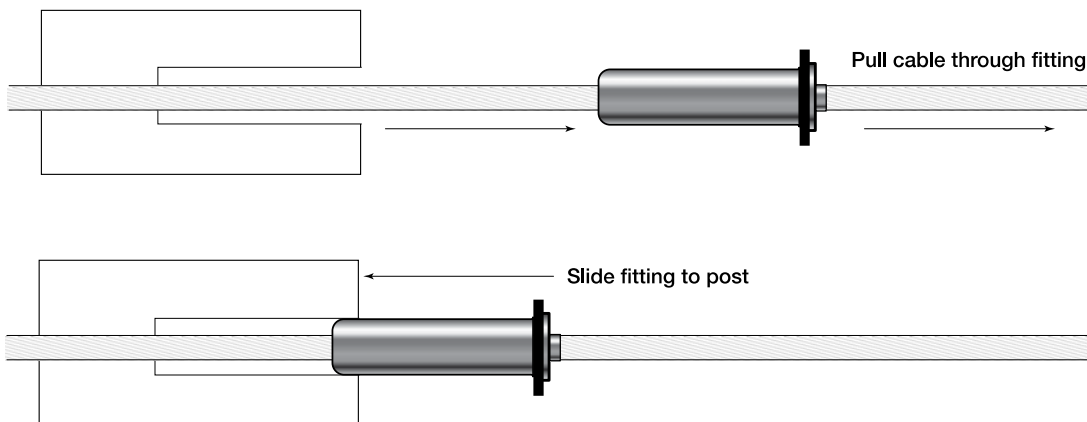

IG-36
4/1/15

Ultra-tec[®]
CABLE RAILING INFILL

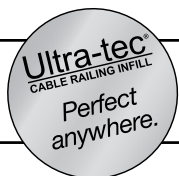

1-800-851-2961 ■ 775-885-1443 ■ Fax 775-885-2734
52 Heppner Drive ■ Carson City, NV 89706
E-mail: info@ultra-tec.com Website: www.ultra-tec.com

Receiver with Push-Lock Stud (Continued)

5. Hold the cable with one hand and slide the Pull-Lock™ fitting into the hole in the post. Press on the back of the Pull-Lock™ fitting to hold it securely in the post and pull the cable through the fitting until it is as tight as you can make it.

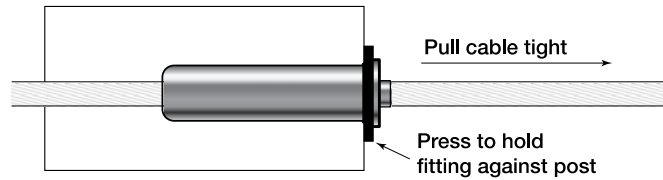

6. Cut the cable flush with the hole in the back of the Pull-Lock™ fitting, using a cut-off wheel (see CUT-OFF KIT in our product catalog).

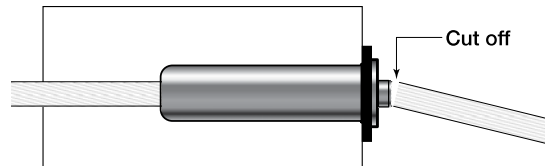

7. Press the cap onto the lip of the Pull-Lock™ fitting.

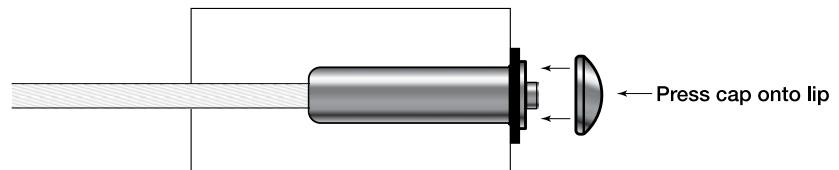

Step C. Tension the cable after all of the fittings have been installed on both end posts.

Grip the wrench flat on the end of the Push-Lock™ Stud at Post A with a 3/8" open-end wrench (to keep the cable from turning), then turn the receiver with a 3/16" Allen wrench until the cables are tight.

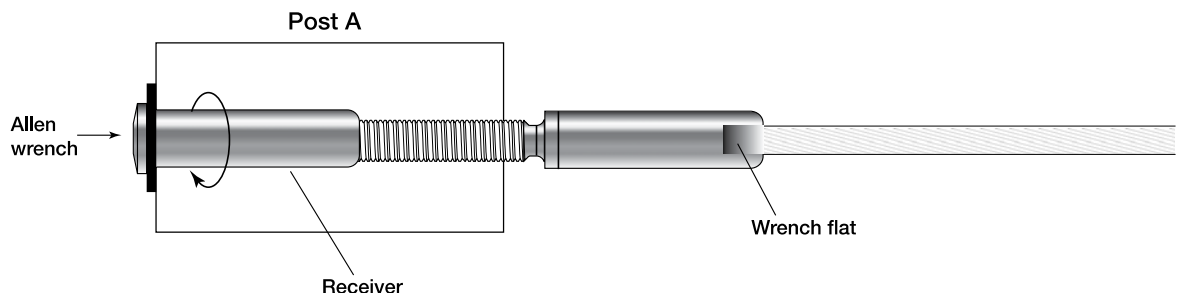

IG-37
4/1/15

Ultra-tec[®]
CABLE RAILING INFILL

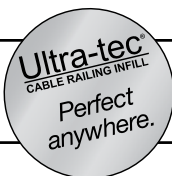

1-800-851-2961 ■ 775-885-1443 ■ Fax 775-885-2734
52 Heppner Drive ■ Carson City, NV 89706
E-mail: info@ultra-tec.com Website: www.ultra-tec.com

Push-Lock Turnbuckle Installation Instructions



The Push-Lock Turnbuckle is a swageless version of the Adjust-A-Body. Both tensioning devices can be used with a hanger bolt, threaded bolt, threaded eye, or anchor bolt end fitting. Depending on the application (wood, metal, or concrete post or stair), make sure the holes are drilled properly in the end post where you will be installing the Push-Lock Turnbuckle.

Push-Lock Turnbuckles are typically used as a second tensioner on a cable run, with the other tensioner being an Adjust-A-Body. The following directions assume this is the case.

1. After your end fittings have been attached to both posts, start on the Adjust-A-Body side (Post A).

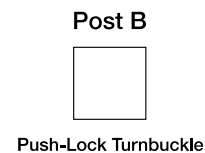
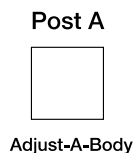

2. Screw the lock nut all the way onto the 2" long machine thread jutting out of Post A.
3. Next, thread the body (already positioned with the ferrule-swaged cable inside) onto the same 2" long machine thread and turn halfway along the threads.

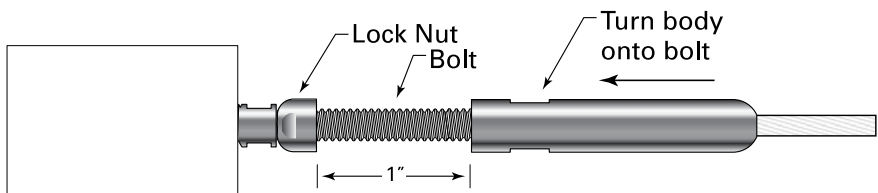

IG-38
4/1/15

Ultra-tec[®]
CABLE RAILING INFILL

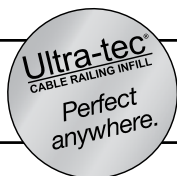

1-800-851-2961 ■ **775-885-1443** ■ **Fax 775-885-2734**
52 Heppner Drive ■ Carson City, NV 89706
E-mail: info@ultra-tec.com Website: www.ultra-tec.com

Push-Lock Turnbuckle (Continued)

4. Run the bare end of the cable through all your intermediate posts and to the end post where you will be installing the Push-Lock Turnbuckle (Post B).

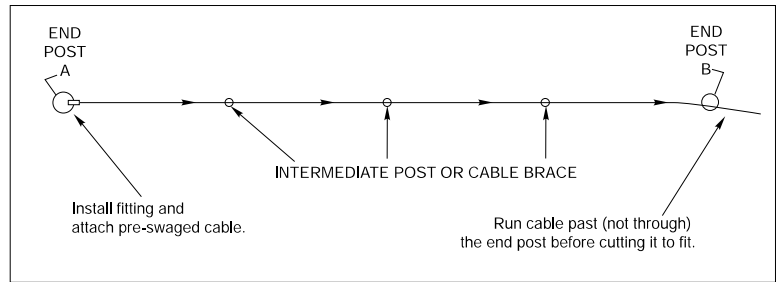

5. Now, on the Push-Lock Turnbuckle side, screw the lock nut all the way onto the 2" long machine thread jutting out of Post B.
6. Next, thread the Turnbuckle body onto the same 2" long machine thread until 1" of thread is showing between the nut and the body.

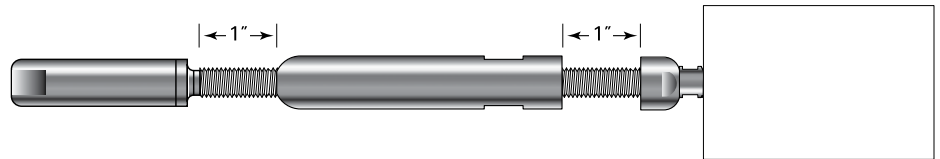

7. Thread the Push-Lock Stud into the Turnbuckle body until there is 1" of thread showing between the Turnbuckle body and the shoulder of the stud.

8. Mark the Push-Lock Stud body at 1-3/16" from the cable entrance of the stud. Holding the fitting, pull the cable taut over the mark on the stud and transfer the mark to the cable. Cut cable at mark.

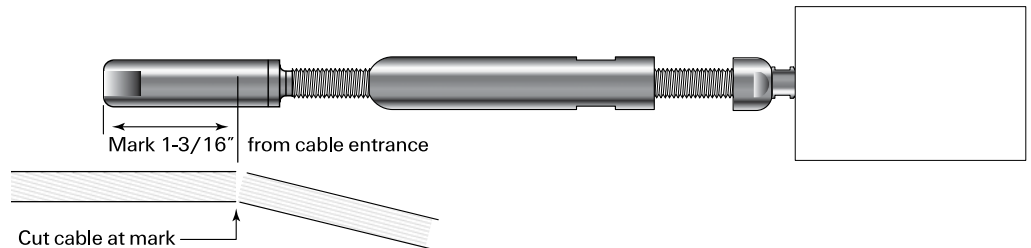

9. At Post A, detach the body from the machine thread jutting out of Post A to perform the next step.
10. At Post B, push the cable into the hole in the stud as far as it will go (approximately 1-1/16"). Twist the cable in the right-hand direction as you push in the fitting. You will feel it slide through the jaws inside the stud.

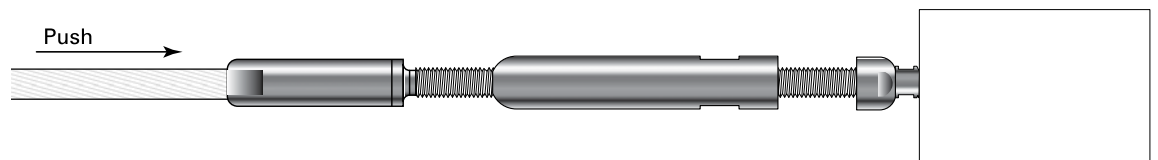

IG-39
4/1/15

Ultra-tec[®]
CABLE RAILING INFILL

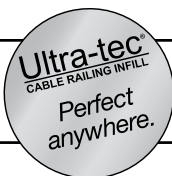

1-800-851-2961 ■ 775-885-1443 ■ Fax 775-885-2734
52 Heppner Drive ■ Carson City, NV 89706
E-mail: info@ultra-tec.com Website: www.ultra-tec.com

Push-Lock Turnbuckle (Continued)

11. At Post A, hand turn the body back onto the machine thread as far as possible.
12. Tension the cable, beginning at Post A, by holding it to prevent the cable from turning while you turn the Adjust-A-Body with a 7/16" open-end wrench. Be careful to protect the cable from damage while tensioning the Adjust-A-Body. Any remaining visible thread may be needed for future tightening.
13. Turn the lock nut against the body and tighten with open-end wrenches.
14. Tension in sequence, beginning with the outside cables and moving back and forth toward the center. (Use image 16)

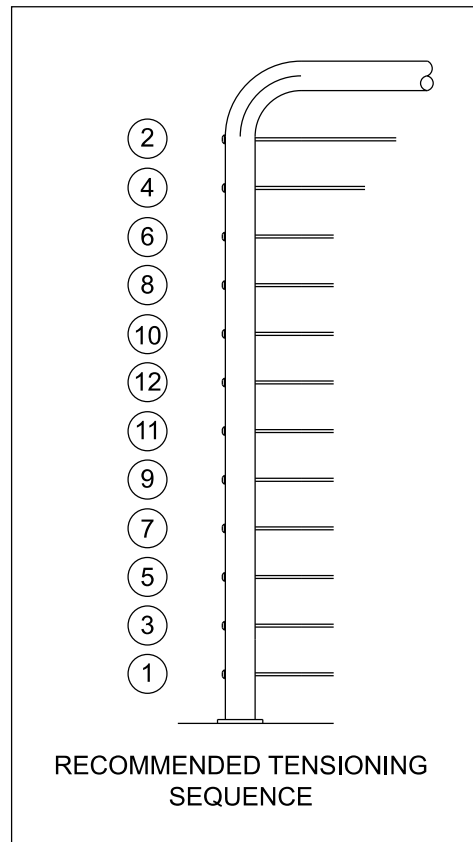
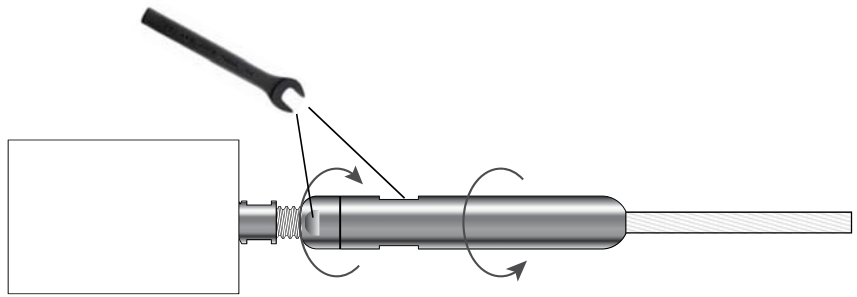

IG-40
4/1/15

Ultra-tec[®]
CABLE RAILING INFILL

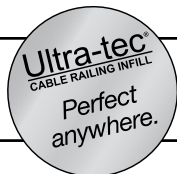

1-800-851-2961 ■ **775-885-1443** ■ **Fax 775-885-2734**
52 Heppner Drive ■ Carson City, NV 89706
E-mail: info@ultra-tec.com Website: www.ultra-tec.com

Push-Lock Turnbuckle (Continued)

15. Go to Post B and finish tensioning using the Turnbuckle. While preventing the Push-Lock Stud from turning by holding it in place with a 3/8" open-end wrench (using wrench flat), turn the body of the Turnbuckle with a 7/16" wrench until the cable is suitably tensioned. Once tensioned, there may be 1/2"-3/4" of thread left showing on either side of the Turnbuckle body. Any remaining visible thread may be needed for future tightening.

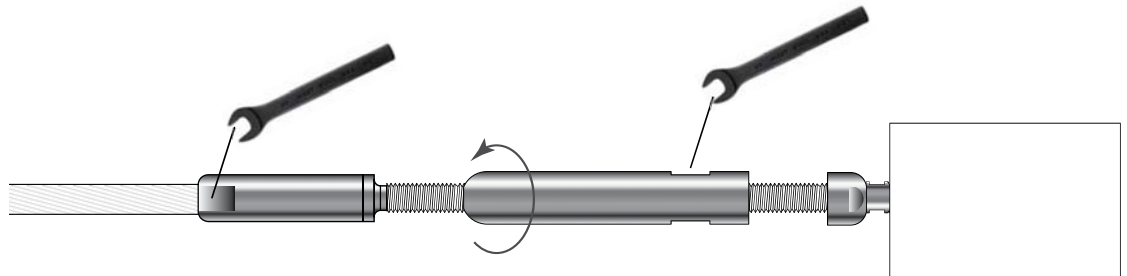

16. Remove 3/8" wrench from the Push-Lock body. Using another 7/16" wrench to prevent the Turnbuckle body from rotating, tighten the nut against the body to lock adjustment.

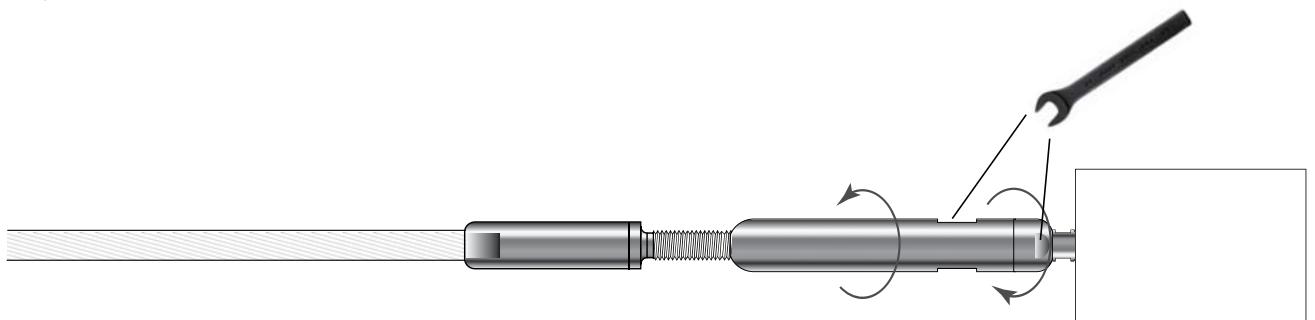

17. Tension in sequence as in Step 14. Finished cables should be tensioned to have only 1/4" of play when finger-pulled.

PL-Key Instructions



For some Push- and Pull-Locks, a release key is available. The key opens the spring-loaded jaws that grip the cable prior to tensioning.

The PL-Key is primarily used when you want to remove the cable from the Push/Pull-Lock during the installation and cable-trimming process. Because it opens the spring-loaded jaws, it also helps you insert the cable into the Push/Pull-Lock if you're having trouble with that step.

While the PL-Key is very helpful prior to tensioning the cable, it is not effective once the cable has been tensioned. The jaws set into the cable and the push/pull-lock's tamper-resistant design prevents you (or anyone else) from removing the cable at this point. More importantly, even if you are able to remove tensioned cable from the Push/Pull-Lock, the fitting's locking mechanism is spent and cannot be re-used.

1. Slide the groove of the PL-Key along the cable until the cable is completely inside the groove. Carefully insert the PL-Key into the Push/Pull-Lock opening.

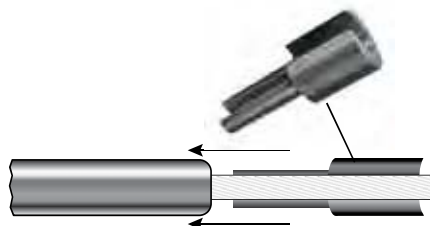

2. Push down until the key bottoms out. You will feel resistance from the spring-loaded jaws as you do so.

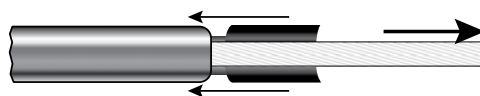

3. Now you may safely remove the cable from the Push/Pull-Lock without damaging the jaw mechanism.

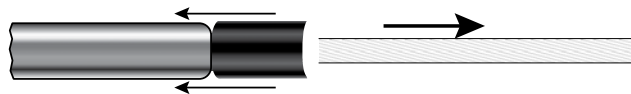

4. Remove the PL-Key and the jaws will reset to their original position, ready to accept and grip the cable again.

IG-42
4/1/15

Ultra-tec[®]
CABLE RAILING INFILL

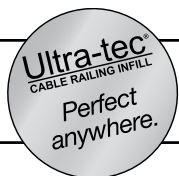

1-800-851-2961 ■ **775-885-1443** ■ **Fax 775-885-2734**
52 Heppner Drive ■ Carson City, NV 89706
E-mail: info@ultra-tec.com Website: www.ultra-tec.com